



Q8™ Tape Library

Installation and Operations Manual

Copyright

© Copyright 2017-2026, QUALSTAR. All rights reserved. This document and the information contained herein are the property of QUALSTAR. No part of this document may be reproduced, transmitted, transcribed, stored in a retrieval system, or translated into any language or computer language in any form or by any means, electronic, mechanical, magnetic, optical, manual, or otherwise, without the express written permission of QUALSTAR.

Trademark Notices

QUALSTAR makes no representation or guarantees with respect to the contents of this document and specifically disclaims any implied warranties of merchantability or fitness for any particular purpose. Further, QUALSTAR reserves the right to revise this publication without obligation of QUALSTAR to notify any person or organization of such revision or changes.

Q8™ is a Trademark of Qualstar Corporation

Revision History

Date	Issue	Revision	Author	Description of changes
2017-10-23	Initial release	01	Kevin Yi	
2018-01-15		02	Kevin Yi	LTO-8 Add
2022-02-11		03	Kevin Yi	LTO-9 Add
2026-04-01		04	Kevin Yi	Gen2 Release

Contacting Qualstar

Sales

Qualstar Corporation
1267 Flynn Road
Camarillo, CA 93012

Sales@Qualstar.com
805-583-7744
877-886-2758 (Toll Free)

Technical Support

Qualstar Corporation
1267 Flynn Road
Camarillo, CA 93012

support@qualstar.com
805-416-7055

For non-urgent questions, please use the form on our website at:

<http://www.qualstar.com/service-requests/>

Product warranty caution

The Q8 Tape Library contains no user-serviceable components. Only an authorized service center should carry out any servicing or repairs. The warranty for the tape library shall not apply to failures of any unit when:

- Any of the tape library components is repaired or modified by anyone other than Qualstar's personnel or approved agent. **Note:** Certain components of the Q8 Tape Library, are identified in this manual as 'field replaceable'. These include the power supply, tape drives, library controller and magazines. User replacement of such complete components with corresponding parts supplied by Qualstar does not affect warranty, provided the user strictly adheres to the instructions herein.
- The tape library is physically abused, or used in a manner that is inconsistent with the operating instructions or product specification defined by Qualstar.
- The tape library fails because of accident, misuse, abuse, neglect, mishandling, misapplication, alteration, faulty installation, modification, or service by anyone other than the factory service center or its approved agent.
- The tape library is repaired by anyone, including an approved agent, in a manner that is contrary to the maintenance or installation instructions supplied by Qualstar.
- The manufacturer's serial number tag is removed.
- The tape library is damaged because of improper packaging on return.

In case of unauthorized repairs or modifications, your warranty becomes immediately void.

General warnings



DANGER

High voltage - Risk of electric shock

- Do not remove cover (or back). No user-serviceable parts are inside.
 - Refer servicing to qualified service personnel.
-



WARNING

Weight of Q8 Tape Library - Risk of personal injury

Before lifting a library:

- Observe local health and safety requirements and guidelines for manual material handling.
- Remove all tape cartridges to reduce the weight.
- Obtain adequate assistance to lift and stabilize the library during installation or removal.

Risk of damage to devices

When placing a library into or removing the library from a rack:

- Extend the rack's leveling jacks to the floor.
 - Ensure that the full weight of the rack rests on the leveling jacks.
 - Install stabilizing feet on the rack.
 - Extend only one rack component at a time.
-



CAUTION

Static sensitive - Risk of damage to devices

- A discharge of static electricity damages static-sensitive devices or micro circuitry.
 - Proper packaging and grounding techniques are necessary precautions to prevent damage.
-



NOTE

- **Ventilation** – Place the product so that its location does not interfere with proper ventilation.
 - **Heat** – Place the product so that its location is away from heat sources.
 - **Power sources** – Connect the product to a power source only of the type directed in the operating instructions or as marked on the product.
 - **Power cord protection** – Place the AC line cord so that it is not possible to be walked on or pinched by items placed upon or against it.
 - **Object and liquid entry** – Ensure that objects do not fall and liquids are not spilled into the product's enclosure.
-

Contents

1	Product Overview and Features	3
1.1	Hardware Configuration.....	3
1.1.1	Q8 Tape Library.....	3
1.2	Front Panel.....	4
1.3	Rear Panel.....	5
1.3.1	Q8 Power supply.....	5
1.3.2	Tape drives.....	6
1.3.3	Library controller.....	7
2	Installation	8
2.1	Location Requirements.....	8
2.2	Serial Attached SCSI (SAS) Requirements.....	8
2.3	Fibre Channel Requirements.....	9
2.4	Installation Precautions.....	11
2.5	Unpacking the library.....	12
2.6	Identifying the product components.....	12
2.7	Removing the shipping lock.....	11
2.8	Rack mounting the library.....	12
2.9	Installing a tape drive.....	14
2.10	Connecting the cables.....	15
2.10.1	Connecting the power cord.....	15
2.10.2	Connecting a Fibre Channel cable.....	16
2.10.3	Connecting a SAS cable.....	16
2.10.4	Connecting an Ethernet cable and a USB device.....	17
2.13	Verifying the host.....	17
2.14	Powering the library up or down.....	17
2.15	Tape cartridges.....	17
2.15.1	Tape cartridge type.....	17
2.15.2	Using and maintaining tape cartridges.....	18
2.15.3	Labeling tape cartridges.....	19
2.15.4	Write-protecting tape cartridges.....	20
2.16	Magazines.....	21
2.16.1	Slot usage.....	21
3	Operating Procedures	22
3.1	Operator control panel (OCP).....	22
	Operating Modes.....	22
3.1.1	OCP Rules.....	22
3.1.2	Power-Up Display.....	23
3.1.3	Note about the LED's.....	23
3.1.4	Input Modes.....	23
3.1.5	Power-Down.....	24
3.1.6	Initial Configuration steps on the OCP.....	24
3.1.7	Login.....	25
3.1.8	Operation.....	25
3.1.9	Configuration.....	26
3.1.10	Maintenance.....	27

3.1.11	Information/Status.....	28
3.1.12	Logout.....	29
3.2	Remote Management Interface (RMI)	29
3.2.1	Overview.....	29
3.2.2	Login	30
3.2.3	Top Banner Elements	31
3.2.4	Left Pane Elements	31
3.2.5	Center Pane Elements.....	32
3.2.6	Configuration Menu.....	33
3.2.7	Maintenance Menu	54
3.2.8	Operation Menu.....	63
3.2.9	Status.....	66
4	Servicing the Library	77
4.1	Possible Tools Needed	77
4.2	Replacing a Tape Drive.....	786
4.3	Replacing a Controller Board	786
4.4	Installation problems	78
4.4.1	Cabling.....	78
4.4.2	Compatibility	78
4.4.3	Backup application installation	79
4.4.4	Device driver installation	79
4.5	Troubleshooting.....	79
4.5.1	Fibre Channel Connection Problems.....	79
4.5.2	SAS Connection Problems.....	79
4.5.3	Power Problems.....	80
4.5.4	Move Problems	81
4.5.5	Media Problems	81
4.5.6	LED is Lit.....	82
4.5.7	Inventory Problems.....	83
4.5.8	RMI Issues	83
4.5.9	Performance Issues	84
4.6	Removing the Magazines	85
4.7	Ejecting a Stuck Tape	85
5	Packaging the unit for transportation	86
6	Technical specifications	87
6.1	Hardware specifications.....	87
6.2	Operating environment.....	87
7	Regulatory Information	88
7.1	Recycling and disposal	88
8	Default Settings	90
9	Glossary.....	90
10	Index.....	92

1 Product Overview and Features

This manual provides information about installing, operating, troubleshooting and servicing a Qualstar Q8 Tape Library. It is intended for system administrators and general users who need physical and functional knowledge of the Q8 Tape Library.

The Q8 Tape Library provides a compact, high capacity, low-cost solution for simple, unattended data backup. It is compatible with most host operating systems and environments provided the host is equipped with the appropriate interface card. However, the library requires either direct support from the operating system or a compatible backup application to take full advantage of its many features.

Major characteristics of the Q8 Library include:

- Platform – support for one half-height LTO7, LTO8, or LTO9 tape drive.
- Connectivity – Fibre Channel (FC) and/or Serial Attached SCSI (SAS) depending upon installed tape drive
- Technology upgrade – tape drive technologies can be upgraded in the field
- Service friendly design – easy access to magazines, tape drives, library controller and power supply for field replacement
- Maximum up time – through advanced error handling and recovery capability

The Q8 Library includes the following features:

- USB interface to enable serviceability features (library and drive firmware upgrades) and/or customized features (storage on demand) implementation
- The library can be operated via the front operator control panel (OCP), over the network or the Internet via the integral remote management unit (RMI), or via the storage interface connection from the host application
- Supports industry standard management protocols such as SNMP (SMI-S future development)
- The Q8 has one mail slot for import/export of cartridges during library operation.
- Media changer with barcode reader
- Rack-mounted or standalone operation

1.1 Hardware Configuration

1.1.1 Q8 Tape Library

Height:	1U	Tape drives:	1 half-height drive
Number of magazines:	2 (4 slots each)	Power supply:	1
Number of mail slots:	1	Library controller:	1
Number of tape slots:	8 (less mail slot)		

1.2 Front Panel

The front panel of the Q8 Tape Library is used to access the power button, operator control panel (OCP), left and right magazines, LED's, and the mail slot.

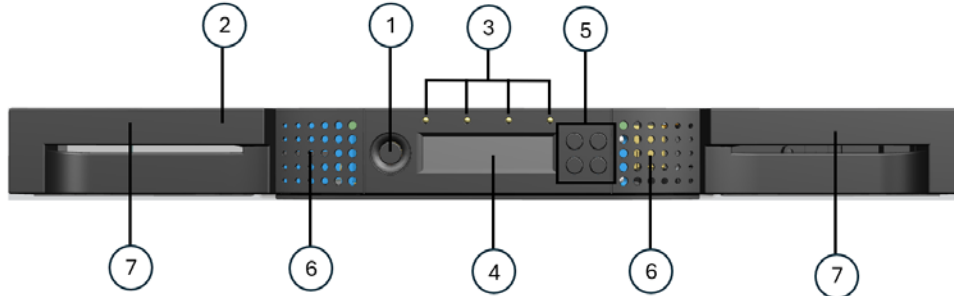

Number	Description
1	Power Button
2	Mailslot
3	Front panel LEDs
4	Front Panel LCD screen
5	Control buttons
6	Air vents
7	Magazine

Figure 1 - Q8 front panel control, indicators and magazines

OCP LEDs: The OCP LEDs indicate system status information.

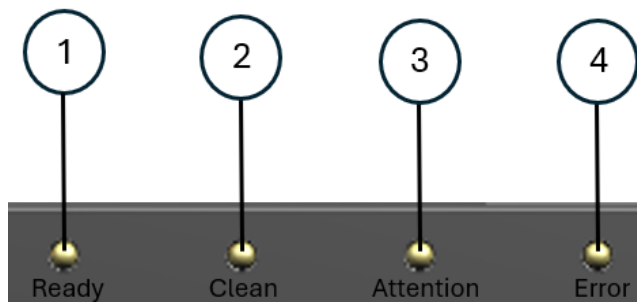

Number	Label	Color	Description
1	Ready	Green	Illuminated when power is on Blinking when there is tape drive or robotics activity.
2	Clean	Amber	Ulluminated when the tape drive has determined that a cleaning cartridge should be used. Cleaning is only necessary when the device directs you to do so. Additional cleaning is not necessary.
3	Attention	Amber	Illuminated if the autolader has detected a condition that requires attention by the operator.
4	Error	Amber	Illuminated if an unrecoverable error occurs. A corresponding error message displays on the LCD screen.

1.3 Rear Panel

The rear panel of the Q8 Tape Library provides access to the drive interface connectors (either SAS or Fibre Channel), the power connector, Ethernet, serial and USB ports and the magazine release holes.

The power supply is on the left side, tape drives are in the middle and the library controller is on the right side of the library.

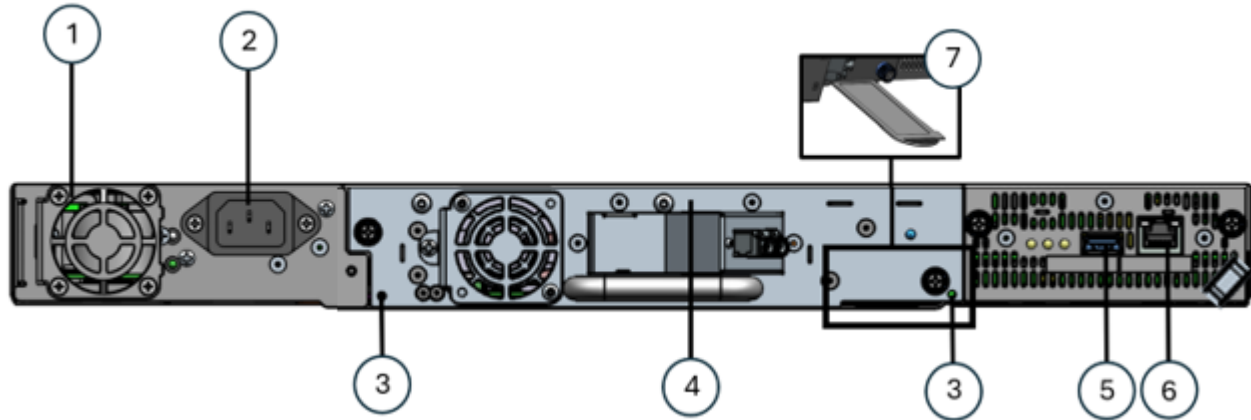

Number	Description
1	Fan
2	Power connector
3	Emergency Magazine release hole
4	Tape drive assembly
5	USB port
6	Ethernet port
7	Pull-out tab containing the serial number and other product information

Figure 2 - Q8 rear panel components

1.3.1 Q8 Power supply

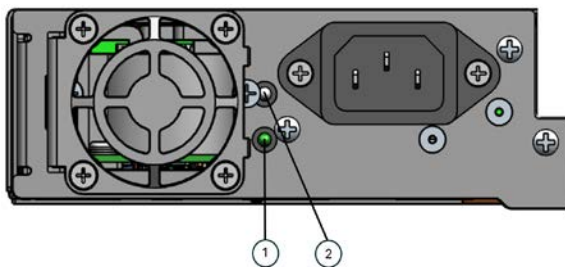

Ref.	Description
1	Green – Module Powered On
2	White – AC power connected, but Module Powered Off

Figure 3 Q8 Power supply

1.3.2 Tape drives

SAS connectors

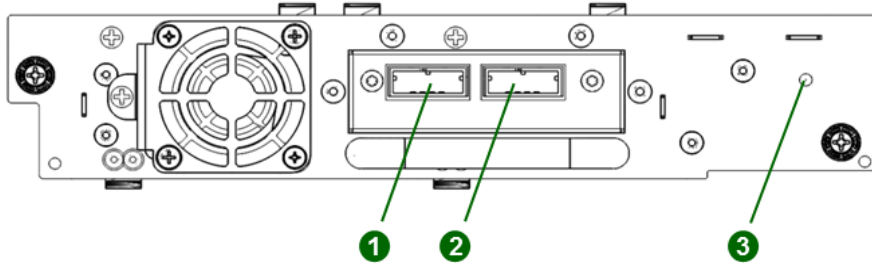

1	SAS Port A*
2	SAS Port B*
3	Tape Drive Power LED, Green
*SFF-8088 connection shown, SFF-8644 connections used for LTO9.	

Figure 4 SAS half-height tape drive

FC connectors

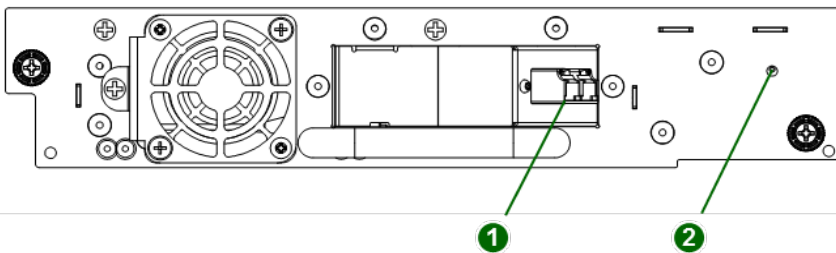

1	FC Port A
2	Tape Drive Power LED, Green

Figure 5 FC half-height tape drive

1.3.3 Library controller

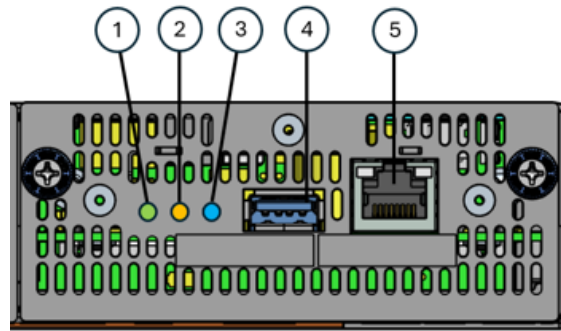

Number	Color	Description
1	Green	Controller health status LED. - Pulsates on and off in approximately one second cycles during normal operation. - Solid green or not illuminated while the autoloader is powered on indicates that the controller is not operating correctly. - Before replacing the controller, power cycle the autoloader, confirm that the controller is faulty.
2	Amber	Error
3	Blue	Unit identifier (UID)
4	-	USB Port
5	-	Ethernet Port

Figure 6 - Q8 Library controller

2 Installation

This section provides instructions for installing the Q8 Tape Library.

2.1 Location Requirements

Criteria	Definition
Rack requirements	Standard 19-inch rack with vertical space of 1U available
Room temperature	10-35°C (50-95°F)
Power source	AC power voltage: 100-127 VAC; 200-240 VAC Line frequency: 50-60 Hz Place the library near to an AC outlet. The AC power cord is the library's main AC disconnect device and must be easily accessible at all times.
Air quality	Place the library in an area with minimal sources of particulate contamination. Avoid areas near frequently used doors and walkways, stacks of supplies that collect dust, printers, and smoke-filled rooms. Excessive dust and debris can damage tapes and tape drives.
Humidity	20-80 percent relative humidity non-condensing
Clearance	Back: Minimum of 15.4 cm (6 inches) Front: Minimum of 30.8 cm (12 inches) – for mail slot Minimum of 60 cm to remove magazines (24 inches) Sides: Minimum of 5.08 cm (2 inches)

2.2 Serial Attached SCSI (SAS) Requirements

Serial Attached SCSI (SAS) is a computer bus technology mainly used to transfer data to and from storage devices, including disk drives and tape drives.

SAS uses serial connections, with a direct connection between the host server and each of the storage devices. This eliminates the need to configure SCSI buses and assign SCSI IDs, as was required for parallel SCSI devices.

Most SAS host bus adapters (HBA) ports have four SAS channels. A tape drive uses one channel, so each HBA port can support up to four tape drives via a fan-out cable. You can use a cable with one connector on each end, but only one channel will be used.



NOTE

The library has a mini-SAS connector on the SAS tape drive. Mini-SAS connectors are keyed.

A SAS tape drive is identified by a unique identifier called a World-Wide Name (WWN) or World-Wide Identifier (WWID). The library assigns the WWID to the drive bay. When a tape drive is replaced, the WWID is re-assigned to the new tape drive.

The operating system tracks the WWID for the tape drive on each HBA channel. Each of the drive connectors on the fan-out cable is associated with an HBA channel. Once a tape drive has been plugged in, it should remain on the same channel to retain the association between the HBA channel and WWID.

2.3 Fibre Channel Requirements

Fibre Channel (FC) allows an active intelligent interconnection scheme, called a Fabric , to connect devices. Everything between the ports on FC is called the Fabric. The Fabric is most often a switch or series of switches that takes the responsibility for routing.

The library allows the selection of the following Fibre Channel port behaviors:

- LN Port (default setting) – an automatic configuration that tries arbitrated loop first, then switched Fabric.

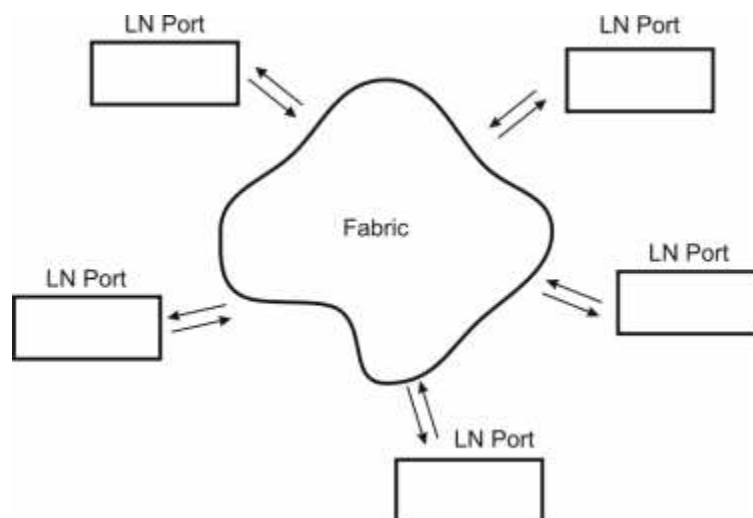

Figure 7 Fibre Channel topology (LN Port)

- L Port – arbitrated loop

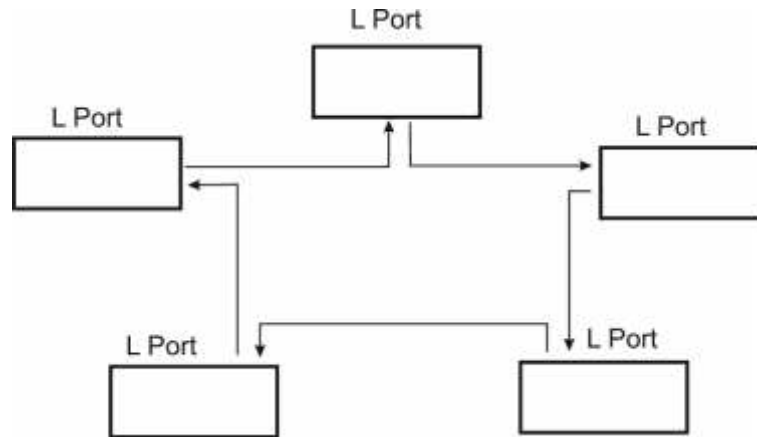

Figure 8 Fibre Channel topology (L Port)

- N Port – point to point protocol in a switched Fabric topology

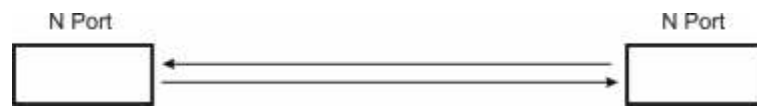

Figure 9 Fibre Channel topology (N Port)

The Fibre Channel tape drive can be connected directly to the server with a host bus adapter (HBA) or through a storage area network (SAN).



NOTE

- Use an appropriate HBA for your tape drive due to performance considerations. A lower throughput HBA might result in performance degradation when backing up highly compressible data to a higher throughput tape drive.
- In a SAN installation, all switches between the host and the library must be of the appropriate type. A lower throughput switch in the path may result in performance degradation. Configure zoning so only the backup servers may access the library.

2.4 Installation Precautions



CAUTION

Static sensitive - Risk of damage to devices

- A discharge of static electricity damages static-sensitive devices or micro circuitry.
 - Proper packaging and grounding techniques are necessary precautions to prevent damage.
 - See **Section 5.2, Electrostatic discharge**
-



WARNING

Weight of Q8 Tape Library - Risk of personal injury

Before lifting a library:

- Observe local health and safety requirements and guidelines for manual material handling.
- Remove all tape cartridges to reduce the weight.
- Obtain adequate assistance to lift and stabilize the library during installation or removal.

Risk of damage to devices

When placing a library into or removing the library from a rack:

- Extend the rack's leveling jacks to the floor.
 - Ensure that the full weight of the rack rests on the leveling jacks.
 - Install stabilizing feet on the rack.
 - Extend only one rack component at a time.
-



NOTE

- Do not expose the library to moisture.
 - Use the library on a firm level surface free from vibration.
 - Do not place anything on top of the library.
-

2.5 Unpacking the library

Before unpacking the library, clear a work surface on which to place the unpacked components. If the library will be installed in a rack, select an open rack location allowing easy access to the host server and an easily accessible power outlet.



NOTE

- If the temperature in the room where the library will be installed varies by 15°C (30°F) or more from the room where the library was stored, allow the library to acclimate to the surrounding environment for at least 12 hours before unpacking it from the shipping container.

1. Before opening and removing the tape library from the box, inspect the container for shipping damage. If you notice any damage, report it to the shipping company immediately.
2. Open the box.
3. Carefully remove the shipping materials from the top of the library.
4. Remove the accessory package and set aside (if included).
5. Remove the two rack rails and set aside (if included).
6. Lift the library out of the carton and remove the bag from the loader. Save the packaging materials for future use.



NOTE

- Do not place the library on either end or sides as this may damage it.

2.6 Identifying the product components

Confirm that you received the following:

1. Q8 Tape Library, including power supply, 1 half-height tape drive (as ordered), library controller, and two tape magazines.
2. Rack mount kit:
 - 2 rack mount rails
 - 1 bag of eight M6 screws for the rack mounting (9.5 mm square holes in the rack column)
 - 1 bag of eight M6 screws for rack mounting (6.85 mm round holes in the rack column)
 - 2 mounting brackets
 - T10 Torx screws to attach the mounting brackets
 - M5 screws to secure the mounting brackets to the rack
3. Power cord

Optional components, depending on the purchased configuration:

1. Cables - for instance Fibre Channel and SAS cables

2.7 Removing the shipping lock



NOTE

- The shipping lock, which prevents the media changer transport mechanism from moving during shipment, must be removed before the library is powered on.

To remove and store the shipping lock:

1. Remove the yellow label that is securing the shipping lock on the top of the library.
2. Remove the shipping lock.

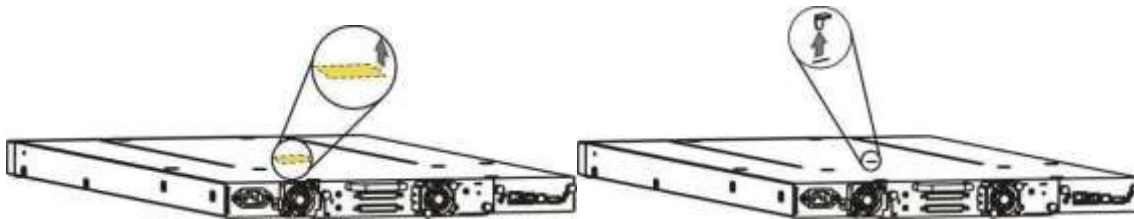

Figure 10 Removing the yellow label and the shipping lock

3. Store the shipping lock in the shipping lock storage location.

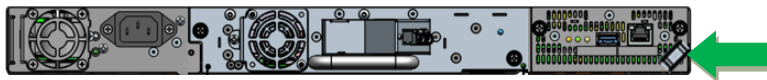

Figure 11 Shipping lock storage location

4. Replace the yellow label on the top of the unit.

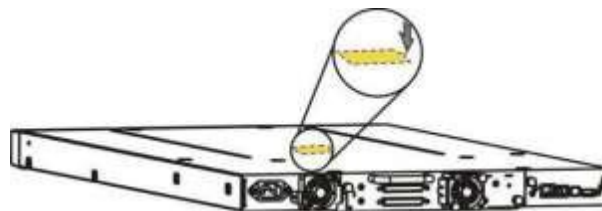

Figure 12 Replace the yellow label

2.8 Rack mounting the library



NOTE

- The rack rail components are optional accessories depending on the ordered configuration. Skip this section, when the rack rail components are not included.

Required tools:

- #3 Phillips screwdriver
- T10 Torx screwdriver

Rack mounting the library:

1. Determine the location in which the library rack is to be installed.
2. Use a pencil to mark the location on each vertical rail in the rack.
3. In the rack mount kit are two sets of eight M6 screws. Determine the type of rack then choose the appropriate type of M6 screws.
4. Secure one rail to each side of the rack in your chosen rack location with a #3 Phillips screwdriver. Insure the rails are mounted level and at the same rack height on each side.
5. Secure both the front and back of each rack rail to the rack.

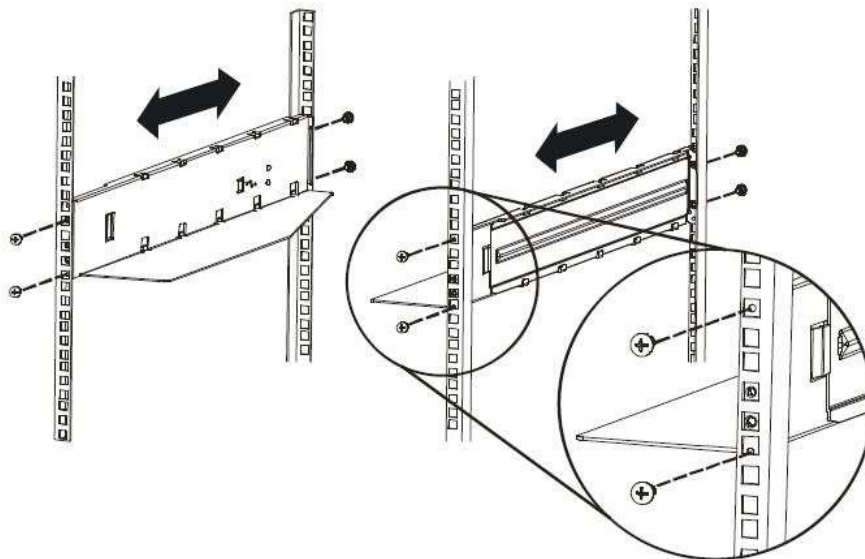

Figure 13 Install the rack rails

6. Install mounting brackets for the library using the Torx screws included in the rack mount kit.

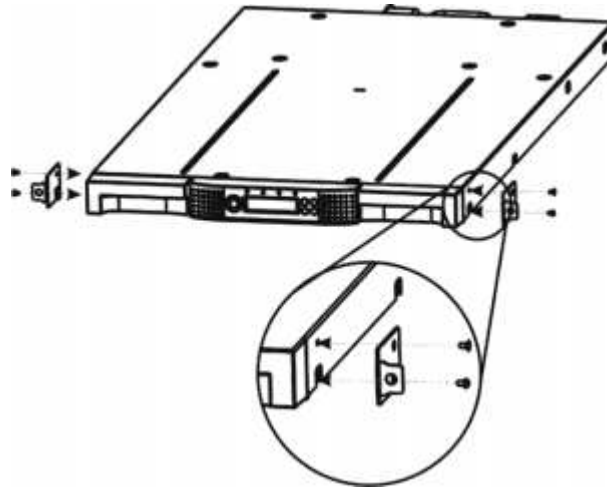

Figure 14 Install the mounting brackets

7. Slide the library onto the rack rails.
8. Secure the library to the rack using a 3# Phillips screwdriver placed through the small holes in the mounting bracket to tighten the M5 screw(s) on each side of the library.

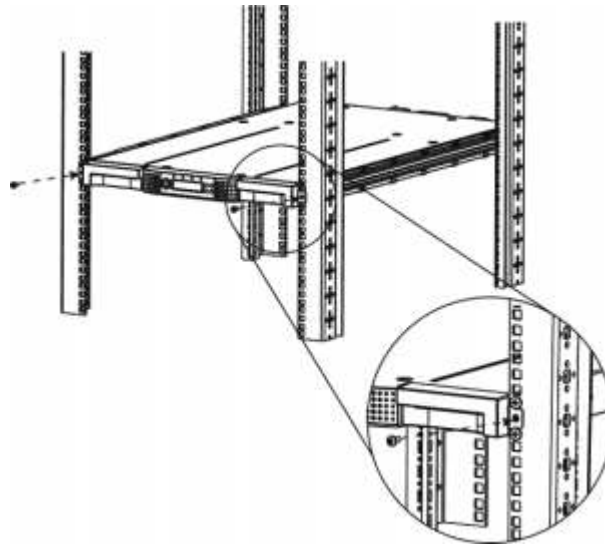

Figure 15 Secure the library to the rack

2.9 Installing a tape drive

A tape drive is installed from the rear of the library. If the library does not already have a tape drive installed, install it now.

Required tool:

- #2 Phillips screwdriver

To install tape drives:

1. The Q8 has space for 1 half-height tape drive.
2. If a drive cover is present, loosen the screws and remove the cover to install one half-height tape drive.
3. When installing the drive, slightly pull out the tab of the product ID label so it does not interfere with the insertion or removal of the tape drive.

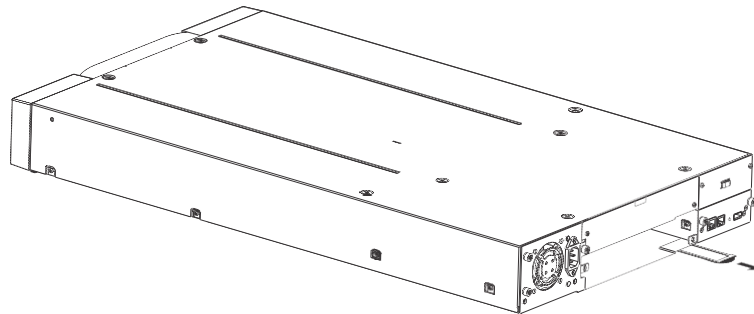

Figure 16 Pullout tab for product ID

4. Before installing the drive, inspect the connectors on it.
5. Insert the tape drive into the drive bay, and align the connectors on the library while supporting the drive.



Figure 17 Install a tape drive

6. Push the tape drive into the drive bay until the tape drive seats itself against the back of the library. If extended, push the tab for the product ID label back into the library.
7. Tighten the blue captive screws with your fingers to secure the tape drive to the library.

2.10 Connecting the cables

2.10.1 Connecting the power cord



DANGER

High voltage - Risk of electric shock

- Use only approved power cords.
 - Observe local health and safety requirements and guidelines for manual material handling.
-



WARNING

Usage of non-approved power cords

- **Risk of personal injury**
- **Risk of damage to devices**

Before connecting a power cord to the library:

- Ensure that the power cord meets individual country specific safety standards.
- Use a sufficient conductor current capacity (amps) to avoid overheating the cord.

The manufacturer disclaims all liability in the event a non-manufacturer approved power cord is used.

To connect the power cord to the library:

1. Plug the female connector of the power cord into the power connector (AC connector) on the rear panel of the power supply.
2. Plug the male connector into an appropriate electrical socket.

2.10.2 Connecting a Fibre Channel cable



NOTE

Use only cables specified for your LTO Fibre Channel tape drive. Each FC tape drive has two FC ports.

- Cable **[Port A]** only.
- Configure **[Port B]** for <Auto Detect> on <Fibre Speed> and <Port Type>.

To connect the FC cable to the tape drive:

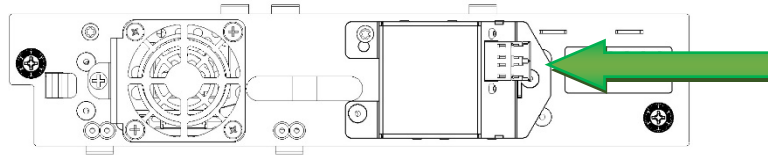

1. Remove the FC port caps if necessary. Attach one end of the FC cable to the port on the tape drive.

Figure 18 Connect the FC cable

2. Attach the other end of the FC cable to a switch or host bus adapter (HBA).

2.10.3 Connecting a SAS cable



NOTE

Use only cables specified for your LTO SAS tape drive. Each SAS tape drive has a mini-SAS connector.

- Mini-SAS connectors are keyed.
- Do not force a SAS cable's mini-SAS connector into the tape drive mini-SAS connector because it might be keyed differently.

SAS signal rates require clean connections and a minimum number of connections between the HBA and the library.

- Do not use adapters or converters between the HBA and the library.
- A maximum SAS cable length of six meters is recommended.

To connect the SAS cable to the tape drive:

1. Plug the HBA end of the SAS cable into the connector on the HBA.
 - If you have a SAS fan-out cable, the end of the cable with only one connector, should be plugged into the connector on the HBA.
 - If you are using a cable with a single connector on each end, plug the other end into the connector on the tape drive.
 - If you are using a SAS fan-out cable, plug one mini-SAS connector into the connector on each tape drive. The unused ends of the SAS fan-out cable are single channel and not suitable for use with disk arrays. Use the other ends to connect tape drives, or coil and secure them to the rack to minimize stress on the connectors.

2.10.4 Connecting an Ethernet cable and a USB device

To connect the Ethernet cable to the library:

The connection to the Ethernet network is via an industry standard RJ45 copper interface on the rear panel of the library. The Ethernet connection is used to access the library RMI over a network.

To connect the library to the Ethernet network, insert the Ethernet cable into the Ethernet port of the library. When the plug is in the correct position, a click should be heard.

To connect the USB device to the library:

The USB port is on the rear of the library. It can be used for firmware upgrades/skin file updates initiated via the operator control panel (OCP).

2.13 Verifying the host

When the host server is powered on, install the software and/or driver(s) that are compatible with the library. Backup software packages may require additional software or licensing to communicate with the library media changer.

To confirm that the host server's operating system has recognized the library, consult the operating system documentation.

2.14 Powering the library up or down

Press the power button on the front panel of the Q8 Tape Library to power it up or down. Powering up can take a few minutes.

2.15 Tape cartridges

Before you begin using the library, an understanding of the media type, use, maintenance, and how to properly label and write-protect your tape cartridges, will help you to prolong the life of your tapes as well as the library.

2.15.1 Tape cartridge type

The tape cartridge types supported depend on the drive types installed. The library will support any type of LTO data cartridge and cleaning cartridge that the installed LTO drive will support.

Tape drive generation	Tape cartridge type
LTO7	<ul style="list-style-type: none"> ▪ Ultrium LTO7, 6.0 TB data cartridge ▪ Universal cleaning cartridge, (50
LTO8	<ul style="list-style-type: none"> ▪ Ultrium LTO8, 12.0 TB data cartridge ▪ Universal cleaning cartridge, (50
LTO9	<ul style="list-style-type: none"> ▪ Ultrium LTO9, 18.0 TB data cartridge ▪ Universal cleaning cartridge, (50 cleans)

	LTO7 tape drive	LTO8 tape drive	LTO9 tape drive
LTO4 media	Incompatible	Incompatible	Incompatible
LTO5 media	Read only	Incompatible	Incompatible
LTO6 media	Read / Write	Incompatible	Incompatible
LTO7 media	Read / Write	Read / Write	Incompatible
LTO8 media	Incompatible	Read / Write	Read / Write
LTO9 media	Incompatible	Incompatible	Read / Write

Some tape drives include support for both rewriteable and WORM data cartridges. Write-Once, Read- Many (WORM) data cartridges provide an enhanced level of data security against accidental or malicious alteration of data on the tape cartridge. The WORM data cartridge can have new data appended to the maximum full capacity of the tape cartridge, but the user will be unable to erase or overwrite any data previously recorded to the cartridge.

2.15.2 Using and maintaining tape cartridges



NOTE

- Do not degauss Ultrium LTO data cartridges! These data cartridges are pre-recorded with a magnetic servo signal. This signal is required in order to use the cartridge with Ultrium LTO tape drives.
- Keep Ultrium LTO cartridges separated from strong magnetic fields such as computer monitors, electric motors, speakers, or X-ray equipment.
- Exposure to electromagnetic energy or magnetic fields can destroy data and the embedded servo code written on the media by the cartridge manufacturer, which can render the cartridge unusable.

To ensure the longest possible life for your data cartridges follow these guidelines before using the library:

- Use only the data cartridges that are designated for your model of the library
- Clean the tape drive when the <Clean Drive> LED is illuminated. Be sure to use only Ultrium universal cleaning cartridges.
- Do not drop an LTO data cartridge. Excessive shock can damage the internal contents of the tape cartridge, or the tape cartridge case itself, making that tape cartridge unusable.
- Do not expose your data cartridges to direct sunlight or sources of heat, including portable heaters and heating ducts.
- The operating temperature range for your data cartridges is 10 to 35° C. The storage temperature range is -40 to +60° C in a dust-free environment in which relative humidity is always between 20 percent and 80 percent (non-condensing).

- If the data cartridge has been exposed to temperatures outside the ranges specified above, stabilize the cartridge at room temperature for the same amount of time it was exposed to extreme temperatures or 24 hours, whichever is less.
- Place identification labels only in the designated area on the tape cartridge. Labels placed in other areas can cause operational problems and the tape to become stuck in the drive.

2.15.3 Labeling tape cartridges

Attaching a barcode label to each tape cartridge enables the library and application software to identify the tape cartridge quickly, thereby speeding up inventory search time. Make it a practice to use bar code labels on your tape cartridges.

Your host software may need to keep track of the following information via the associated barcode:

- Date of format or initialization
- Tape's media pool
- Data residing on the tape
- Age of the backup
- Errors encountered while using the tape cartridge (to determine if the tape cartridge is faulty).



NOTE

- The misuse and misunderstanding of bar code technology can result in backup and restore failures. To ensure that your bar codes meet Qualstar's quality standards, always purchase them from an approved supplier and never print bar code labels yourself.

Ultrium tape cartridges have a recessed area located on the front of the cartridge next to the write-protect switch. Use this area for attaching the adhesive-backed bar code label. Only apply labels as shown in **Figure 19**.

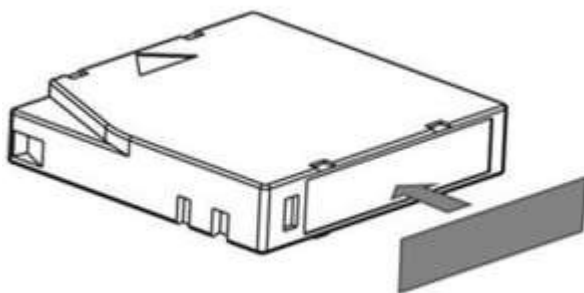

Figure 19 Proper barcode label placement

**NOTE**

- The bar code label should only be applied with the alpha-numeric portion facing to the left- side of the tape (toward the write protect switch) and within the marked Barcode label area.
- Never apply multiple labels onto a cartridge, as extra labels can cause the cartridge to jam in a tape drive.

2.15.4 Write-protecting tape cartridges

All rewritable data cartridges have a write-protect switch to prevent accidental erasure or overwriting of data. Before loading a cartridge into the library, make sure the write-protect switch on the front of the cartridge is in the desired position.

- Slide the switch to the right to write-protect the cartridge. A small padlock symbol is visible indicating that the cartridge is write-protected.
- Slide the switch to the left to allow the Library to write data to the cartridge.

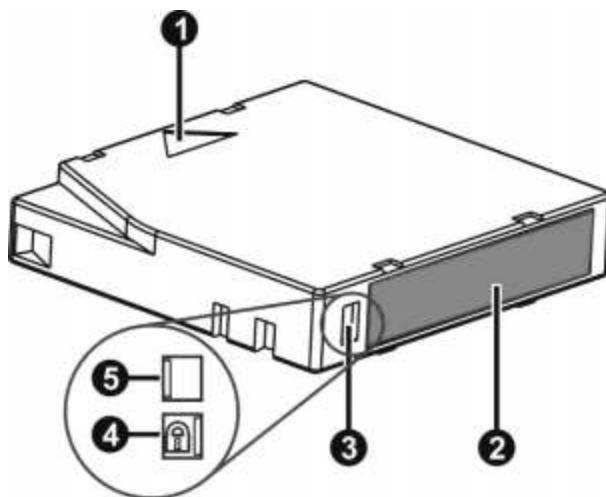

Ref.	Description
1	Insertion arrow
2	Barcode label
3	Write-protect switch
4	Write-protected
5	Write-enabled

Figure 20 Write-protecting a tape cartridge

2.16 Magazines

The Q8 Tape Library makes use of removable magazines. Tape cartridges are stored in the magazines. Each magazine can be individually removed, or inserted. Each magazine inserted in the library, is locked into position, to prevent unauthorized removal. Access to unlock the magazines can be password protected. For safety reasons, removal of a tape magazine disables media changer motion.

The magazines can be unlocked via the Operator Control Panel (OCP) or the Remote Management Unit (RMI).

In case the OCP or RMI initiated process fails or the library no longer has power, a manual emergency release is available.

2.16.1 Slot usage

Each magazine contains 4 slots for tape cartridge storage. However, the front slot in the left-hand magazine can function as a "mail slot".

The mail slot is used to import/export individual tape cartridges without interrupting the library operation. The command to open the mail slot may be denied if the media changer is busy with some operation. In that case, "Busy" is displayed on the OCP and the command has to be repeated once the media changer operation is finished.

3. Operating Procedures

This section provides information about operating and configuring the Q8 Tape Library.

3.1 Operator control panel (OCP)

The autoloader OCP

The OCP has a power button, navigational buttons, an LCD screen, and four LEDs.

With the OCP you can monitor, configure, and operate many autoloader functions.

To power on the autoloader, press the power button. To power off the library, press the power button for five seconds and then release it.

Use the four OCP buttons to navigate the OCP menu and enter information.

Operating Modes

The OCP operates in two basic modes:

1. User interaction mode: This mode is employed when a user is pushing buttons on the operating panel.
2. System driven mode: This is the normal mode of operation. In this mode, the operating panel displays status associated with the actions that were caused from commands issued from the host software application. Actions like loading, rewinding or moving tape cartridges will be displayed.

Whenever an operating button is pressed and released, the operating panel automatically transitions to user interaction mode. The user interaction mode will be active until 3 minutes after the user stops pushing buttons, or the requested media changer activity stops – whichever is longer. At this time, the operating panel will return to the system driven mode.

In the event that the administrator-programmed user security feature is in use, the user interaction mode is restricted to the information and login menu screens, until a login with correct PIN is entered.

3.1.1 OCP Rules

OCP commands obey the following basic rules:

1. Any operational conflict between commands received from the host interface or RMI and those entered via the front panel will be avoided with a reservation mechanism on a 'first-come, first-served' basis.
Any reservation by OCP is cancelled by an OCP logout or timeout, which cancels the User Interaction Mode.
2. The library firmware will not allow a user to select an impossible request. Those situations include, but are not limited to:
 - Moving a tape cartridge from any source to a full magazine slot
 - Moving a tape cartridge from an empty magazine slot
 - Loading a tape cartridge from any source to a full tape drive
 - Unloading a tape cartridge from an empty tape drive
3. Any error detected by the library or drive controller and not recoverable through predetermined firmware algorithms will be considered as fatal. An error code will be displayed on the LCD and the error LED will become illuminated. The error code will remain on the OCP until a button is pressed, which will cause the OCP to return to the home screen.
4. Numeric error codes are only used for unrecoverable, fatal errors (see **Section 4.7.5, Main**

error codes), otherwise text status messages are provided.

3.1.2 Power-Up Display

When the library powers up or resets, it goes through several internally controlled processes that initialize and prepare the unit for normal operation. These processes are called Power-On-Self-Test (POST). While the POST is in process, the OCP will display appropriate information to keep the user informed. When the library finishes POST, it will display the current drive mount status in the OCP home screen. If the drive is empty, the OCP will display Drive Ready.

3.1.3 Note about the LED's

All LED's are updated during power up and reset sequences. Upon power up or software reset, the library will illuminate all LED's at some point during the POST process. This will help the user to verify whether all LED's are functional. When initialization starts, all LED's will be extinguished and the ready/activity LED will flash at approximately two-second intervals. When the mechanical initialization is complete, the ready/activity LED will stop flashing and remain constantly illuminated.

If a library failure occurs, the ready/activity LED will be turned off and the error LED will be illuminated. The OCP will also display a specific error code to help identify the failure.

The following are additional operational details regarding the LED's.

- The <Ready/Activity> LED will be lit any time the unit is powered on and functional (i.e. successfully completed the power-on self-test). The LED will blink whenever there is any tape library or drive activity. The LED will also blink when the unit is offline.
- The <Clean> LED will only be lit when a 'cleaning required' has been issued by one of the drives. The LED will be turned off after a successful drive cleaning operation is performed to the requesting drive.
- The <Media Attention> LED will indicate that there is a piece of LTO media which is bad, marginal or invalid. The LED will be cleared when all such cartridges have been exported from the tape library.
- The <Error> LED will be lit when there is an unrecoverable (i.e. hard) drive or tape library failure. This will occur simultaneously with the hard error message displayed on the screen; the LED will remain illuminated until the error state is resolved.

3.1.4 Input Modes

There are several modes for entering values in the different menu items. These values may be selectable predefined values, toggle values (e.g. on/off) or numerical values like network addresses.

Selectable predefined values

After navigating to the menu item, the various predefined values can be selected with the <DOWN> and <UP> buttons. As soon as the display shows the desired value, it may be confirmed by pressing the <ENTER> button.

Toggle values

Toggle values are used to switch between two different states like 'on' and 'off'. After navigating to the menu item, the display shows its current state. Pressing the <ENTER> button will select the item, whose value may then be toggled using the <UP> and <DOWN> buttons. Pressing <ENTER> again sets the item to the displayed value.

Numerical values

Numerical values are needed for network addresses, PIN entries, and other configuration entries. After navigating to the menu item to be changed, the actual value will be displayed and the cursor stays on the first digit. The value may be incremented / decremented with the <DOWN> and <UP> buttons.

After pressing the <ENTER> button to select the displayed value, the cursor moves to the next editable digit. Each digit can be changed in the same way. After pressing the <ENTER> button at the last digit, the complete entry will be stored. Pressing the <CANCEL> button will cancel the whole edit process and the old value will be restored.

3.1.5 Power-Down

Pressing the Power button on the library while it is operational will initiate a controlled power down.

The following operations will take place before the unit shuts down completely:

- The display indicates with an appropriate message that the shutdown is in progress.
- The library controller finishes all ongoing loader and drive activities.
- The media changer is moved to its home position.
- The library controller switches off the power supply's secondary side.



NOTE

- The shutdown process may be aborted by pressing the cancel button within the first 3 seconds.

3.1.6 Initial Configuration steps on the OCP

1. Log into the Operator Control Panel (OCP) as Administrator

(press any key > Select User: "ADMINISTRATOR" PIN:0000)

2. Verify/Change network settings

(Configuration > Network)

3. Setup partition

After logging in the first time you will be prompted that the library has no default partition. The library will remain OFFLINE to connected hosts until a valid partition is created.

4. Create a partition using the Basic or Expert Partition Wizard

(Configuration > Partitions > Basic or Expert Wizard)

5. Complete initial Configuration

(Complete any other configuration details required for your installation from the RMI, including date/time settings.)



NOTE

On the very first power up of the library the user is prompted to walk through the Initial Configuration wizard. It is recommended to walk completely through the wizard and finish the wizard by pressing the **Finish Button**. Otherwise with every login on the OCP the user will be prompted again to walk through the wizard.

3.1.7 Login

1. Press **Enter** to get to the login screen
2. On the Login screen use the Up/Down arrows to toggle between the User accounts. Press Enter to select the desired account.
3. Enter the 4-digit PIN of the user account that was selected.
4. Once the PIN is accepted, the Information/Status screen appears.

3.1.8 Operation

Use the Up/Down buttons and go to the Operation menu to access the operation features.

The Operation Menu provides the following options:

Magazine Unlock Left

Press Enter and the left magazine can be pulled out.

Magazine Unlock Right

Press Enter and the right magazine can be pulled out.

! **IMPORTANT** Wait before pulling out the magazine until the LED is quickly flashing and OCP message says that the magazine is unlocked



NOTE

- Opening a magazine will take the library off-line.
- The magazines will relock after 30 seconds.

Mailslot Unlock

! **IMPORTANT** The mailslot must be enabled through the RMI for the Mailslot Unlock option to appear on the OCP.

Press Enter on Mailslot Unlock. Pull the mailslot.

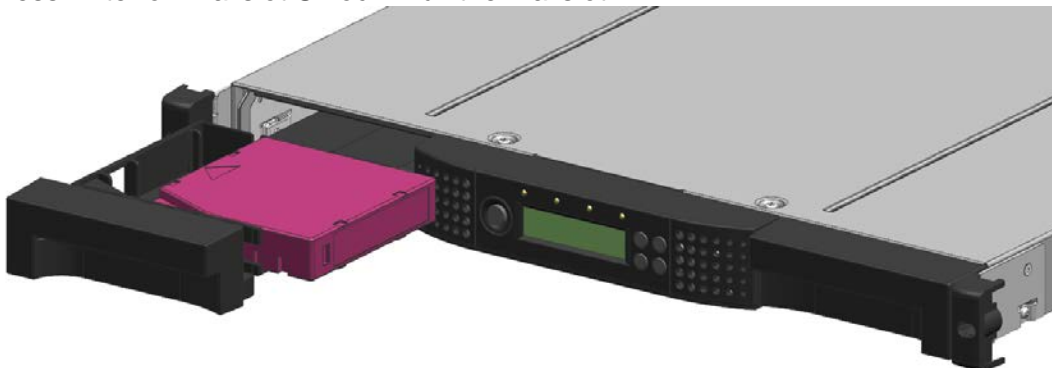

Figure 21 Open Mailslot

3.1.9 Configuration

Use the Up/Down buttons and go to the Configuration menu to access the configuration features.

The Configuration Menu provides the following options:

Library

After pressing Enter at the Configuration Menu, the Library screen appears.

The Library Menu provides the following Submenus:

Save Configuration to USB

Use this option to save the library's current configuration settings to a USB device.

After pressing enter on the Library screen, the Save Configuration to USB screen appears.

Press enter to enter the screen. Insert the USB device and press Enter.

Restore Config from USB

Use this option to restore the library's configuration settings from a previously saved configuration to a USB device.

After pressing enter on the Library screen, the Save Configuration to USB screen appears.

Use the Up/Down buttons and go to Restore Config from USB and press Enter.

Insert the USB device and press Enter to restore the configuration.

Reset to Default Settings

Reset to Manufacturing Settings



IMPORTANT

The difference between Default and Manufacturing settings is that a Manufacturing reset will revert the library back to the settings it had when it left the factory. User and Network configuration settings will be reset. For most cases, the Reset to Default Settings should be used.

Network

After pressing Enter at the Configuration Menu, the Library screen appears. Use the Up/Down buttons and go to the Network screen and press enter.

The Network Menu provides the following Submenus:

Network Type

The Network Type selects the Network protocol which should be used.

IPv6

IPv4

IPv4/IPv6

If IPv6 is selected no further settings are available. For IPv6, "Stateless" will be configured. Additional settings for IPv6 can be found in the RMI.

For IPv4 or IPv4/IPv6, the following settings are available.

Mode – DHCP or Static

If DHCP is selected and confirmed, the configuration will be activated. No other settings are required.

If Static Mode is selected you need to enter the following information: IP Address, IP Netmask, IP Gateway.

After the Gateway address is entered a confirmation screen will appear so you can confirm or cancel the modification.

Users

After pressing Enter at the Configuration Menu, the Library screen appears. Use the Up/Down buttons and go to the Users screen and press enter.

The User Menu provides the following Submenus:

Reset RMI PW

Use this option to reset the RMI Password

After pressing Enter on the Users Menu, the Reset RMI PW screen appears.

Press Enter to reset the RMI Password.

RMI Restricted Login

Use this option to disable the use of the RMI.

After pressing Enter on the Users Menu, the Reset RMI PW screen appears. Use the Up/Down buttons and go to the RMI Restricted Login screen and press Enter.

Configure PIN

Use this option to update the PIN.

After pressing Enter on the Users Menu, the Reset RMI PW screen appears. Use the Up/Down buttons and go to the Configure PIN screen and press Enter.

Enter the new PIN

Verify the new PIN

Press Enter to Save the new PIN

3.1.10 Maintenance

Use the Up/Down buttons and go to the Maintenance menu to access the maintenance features.

The Maintenance Menu provides the following options:

Save Log to USB Device

Use this option to save the library logs to a USB device.

After pressing Enter on the Maintenance Menu, the Save Log to USB Device screen appears.

Press Enter, insert a USB device and press Enter.

Upgrade Firmware from USB

Use this option to upgrade the library's firmware. Make sure to have the appropriate firmware saved to the USB device.

After pressing Enter on the Maintenance Menu, the Save Log to USB Device screen appears.

Use the Up/Down buttons and go to the Upgrade Firmware from USB screen. Press Enter, insert the USB device and press Enter.

Save Drive Dump to USB

Use this option to save the drive dump to a USB device.

After pressing Enter on the Maintenance Menu, the Save Log to USB Device screen appears. Use the Up/Down buttons and go to the Save Drive Dump screen. Press Enter, insert the USB device and press Enter.

Upgrade Drive from USB

Use this option to upgrade the drive's firmware. Make sure to have the appropriate firmware saved to the USB device.

After pressing Enter on the Maintenance Menu, the Save Log to USB Device screen appears. Use the Up/Down buttons and go to the Upgrade Drive from USB screen. Press Enter, insert the USB device and press Enter.

3.1.11 Information/Status

Use the Up/Down buttons and go to the Information/Status menu to access the information/status features.

The Information/Status Menu provides the following options:

Library Status

Use this option to see basic library information.

After pressing Enter on the Information/Status Menu the Library Status screen appears. Press Enter to see library information.

Use the Up/Down buttons to see the following information:

Total Inventory
Moves
Power on Time
Max Temperature
Slots Empty
Vendor ID
Product ID
Library Name
Serial Number
MAC Address
Magazine Inventory

Network Status

Use this option to see the configured Network settings.

After pressing Enter on the Information/Status Menu the Library Status screen appears. Use the Up/Down buttons and go to the Network Status screen. Press Enter to see network information.

Use the Up/Down buttons to see the following information:

If IPv4 is configured:

Protocol
DHCP
IPv4 Address
IPv4 Netmask
IPv4 Gateway
MAC Address

If IPv6 is configured:

IPv6 Mode

IPv6 Address

IPv6 Gateway

**NOTE**

Due to the length of the IPv6 Address and Gateway, press Enter on the item to enter scroll mode. Once in Scroll mode, use the Up/Down buttons scroll left/right to see the full address information. Press Enter to exit scroll mode.

Drive Status

Use this option to see information about the installed tape drive.

After pressing Enter on the Information/Status Menu the Library Status screen appears. Use the Up/Down buttons and go to the Drive Status screen. Press Enter to see drive information.

Use the Up/Down buttons to see the following information:

Powered
Activity
Load Status
Temperature
Enabled
LUN Master
Port A Connected
Port A Speed
Port A Type
Port A ID

**NOTE**

If installed drive has 2 ports, Port B information will also be listed

Firmware Revision
Vendor ID
Product ID
LTO Generation
Interface Type
Serial Number

3.1.12 Logout

Use the Up/Down buttons and go to the Logout screen to Logout of the OCP session.

Press Enter and go to Logout Yes and press Enter.

3.2 Remote Management Interface (RMI)**3.2.1 Overview**

The RMI lets you monitor and control the library from any computer connected to your network. The RMI hosts a dedicated, protected Internet site that displays a graphical representation of the

After establishing a network connection to the library, open any HTML browser and enter the IP address of the library. To allow access from the RMI, you must first set the desired static IP address at the OCP or configure the library to use DHCP.

When possible, it is recommended that the RMI be used as the primary library interface because it provides access to additional features and is easier to use. However, the RMI is not required to use the product, except to configure advanced features, such as SNMP, IPv6, encryption, and partitions.

Before using the RMI, you must configure the library network settings with the OCP. This can be done with the Initial Configuration Wizard. See **“Using the Initial Configuration Wizard”**.

To start the RMI, open the latest version of a supported HTML browser and enter the IP address of the library in the browser’s address bar. Supported browsers include Edge, Firefox, Chrome and Safari.



NOTE Only HTTPS supported. HTTP is not supported.

3.2.2 Login

To login to the library on the RMI:

1. Open a supported web browser and enter the IP address of the library in the browser’s address bar.
2. Select the **User**.
3. If required, enter the **Password**.
4. Click **Login**.

The screenshot shows a login interface with a 'User' dropdown menu set to 'administrator', a 'Password' text input field, and a 'Login' button below it.

The user levels are:

- **User** – No password is required (leave the **Password** blank unless the user password has been set in the **Configuration > User Accounts** page). This account provides access to status information only.
- **Administrator** – The administrator password is required to login as the administrator. The default administrator password is **adm001**. The administrator password can be changed in the **Configuration > User Accounts** page. This account has access to all functionality except for the log configuration, Security and Service features.
- **Security** – The security password is set at the factory to **sec001**. The security password can be changed in the **Configuration > User Accounts** page. This account has access to all functionality except the log configuration and Service. This account is not allowed to modify passwords for other user roles nor OCP PINs.
- **Service** – **Access to this user is by Service personnel only**. The service password is set at the factory. Both the administrator and service passwords are required for a service person to enter the service area.

The library main screen is organized into the following regions:

- **Top Banner** - Contains the home button and displays the overall status and information about the library and user
- **Left Pane** - Displays the library identity and system status
- **Center Pane** - Provides access to operate and configure the library and to view additional status information
- **Right Pane** - Displays a log of recent events

Serial #: DE64011238
 Hostname: TL-1EE7F2
 IPv4: 10.252.2.125
 Firmware: 1.0.0-A000

✓ System
 1 Drive
 0/8
 Empty

Open Mailslot Open Magazine





Configuration Maintenance

Operation Status

Recent Events:

- 24.04.2026 19:58:20 A user has been logged out of the OCP interface by another user
- 24.04.2026 19:58:19 A user logged in at the RMI interface
- 24.04.2026 19:55:33 A user logged in at the OCP interface
- 24.04.2026 16:33:32 A user was logged out of the OCP interface due to a timeout
- 24.04.2026 16:21:49 A user logged in at the OCP interface
- 23.04.2026 23:25:43 A user was logged out of the OCP interface due to a timeout
- 23.04.2026 23:17:42 A user has been logged out of the RMI interface by another user
- 23.04.2026 23:17:18 A user logged in at the OCP interface
- 23.04.2026 23:14:42 A user logged in at the RMI interface
- 23.04.2026 22:46:32 A user was logged out of the OCP interface due to a timeout

3.2.3 Top Banner Elements

-  – **Home Icon** – Returns to the library main screen
- **Library Health** – An icon indicating the overall health status of the library
 -  – The green check mark Status OK icon indicates that all library components are fully operational and that no user intervention is required.
 -  – The yellow triangle exclamation point Status Warning icon indicates that user attention is necessary, but that the library can still perform most operations. Click the icon to display the event ticket log.
 -  – The red circle X Status Error icon indicates that user intervention is required and the library is not capable of performing some operations. Click the icon to display the event ticket log.
- **Status** – The status of the library robotic
 - **Idle** – The library robotic is ready to perform an action.
 - **Moving** – The library robotic is moving a cartridge.
 - **Scanning** – The library robotic is performing an inventory of cartridges.
 - **Offline** – The library robotic has been taken off line by the library.
- **Library Time & Date** – helpful when analyzing event logs and support tickets, and might be needed when contacting support.
- **User** – The user account for this session.
- **Logout** – Logs out of this session.
- **?** – Accesses online help.

3.2.4 Left Pane Elements

- **Library Status** – Overall library confirmation and status
 - **Serial #** – The Base Module serial number

- **Hostname** – The library hostname
- **Network Configuration** – The IP version (IPv4 or IPv6) and IP address
- **Firmware** – The library firmware version
- **System Status Overviews** – A summary of system health. Click the system status area to select the system.
 - System Health Icon
 - The green check mark Status OK icon indicates that the library and each of its components are fully operational and that no user intervention is required.
 - The yellow triangle explanation point Status Warning icon indicates that user attention is necessary, but that the library can still perform most operations.
 - The red circle X Status Error icon indicates that user intervention is required and the library is not capable of performing some operations.
 - Drive Status – The number of drives installed in the module and the health of each drive. Click on the drive to display drive configuration and status information in the center pane.
 - A black square indicates that the drive is fully operational and that no user intervention is required.
 - A yellow square indicates that user attention is necessary, but that the drive can still perform most operations.
 - A red square indicates that user intervention is required or the drive is not capable of performing some operations.
 - Magazine Slot Usage – The number of cartridge slots available and the number in use.
 - Drive Operation Status – The \ current drive activity for each drive in the module. The drive operation status is only displayed for the selected module.
 - Write – The drive is performing a write operation.
 - Read – The drive is performing a read operation.
 - Idle – A cartridge is in the drive but the drive is not performing an operation.
 - Empty – The drive is empty.
 - Encryp – The drive is writing encrypted data.

3.2.5 Center Pane Elements

- **Open Mailslot** – (Administrator user only) Click to unlock the mailslot on the selected module. Mailslots must be enabled before the slots can be used as mailslots. See “**Enabling or Disabling Mailslots**”.
- **Open Magazine** – (Administrator user only) Click to unlock a magazine in the selected module. Only one magazine in the library can be open at a time. See “**Opening a Magazine**”.
- **Configuration** – (Administrator user only) Click to configure the library. See “**Configuring the Library**”.
- **Maintenance** – (Administrator user only) Click to access maintenance functions. See

“Maintaining the Library”.

- **Operation** – (Administrator user only) Click to access operation functions. See “**Operating the Library**”.
- **Status** – Click to access status information. See “**Viewing Status Information**”.

3.2.6 Configuration Menu

Configuration > System > Save/Restore Configuration



Saving the library configuration to a file

Use this option to save the current library settings to a file. A saved configuration file will make it easier to restore the library configuration settings if a problem occurs when changing/adding features to the library. A saved configuration file can also be used in case the controller board is replaced and/or settings are lost.

1. Navigate to the **Configuration > System > Save/Restore Configuration** screen as shown above.
2. Click **Save**. Starts to download the configuration file to the browser or system running the RMI.

Restoring the library configuration from a file

1. Navigate to the **Configuration > System > Save/Restore Configuration** screen.
2. Click **Browse** to navigate to and select the configuration file. The file has to be a zip file.
3. Select the file and press **Upload File & Restore**. Starts the uploading process and restores the configuration file from the system running the RMI.

Resetting the default settings

To reset the library configuration to the default settings, click **Reset Default Settings**. For the default settings, see “**Defaults and Restore Defaults Settings**”.

Resetting the List of Known Drives and Modules

To reset the List of Known Drives and Modules, click **Reset**. This will remove Modules and Drives that have been physically removed from the library from the library configuration.

Configuring the Date and Time Format

To configure date and time format parameters and to use an SNTP server, from the Configuration area, navigate to the **System > Date and Time Format** screen.



NOTE

The library does not adjust its time for daylight saving time; the time must be adjusted manually.

Configuration > System > Date and Time Format

▼ Time Zone

▲ Date/Time Format

Time Format: 24 Hours (hh:mm:ss) ▼

Date Format: (DD.MM.YYYY) ▼

Submit

To set the desired time zone, select **Time Zone**.

A list of continents, countries, and regions is displayed. When an item preceded with '>', for example > **US**, is selected, a submenu is displayed in the next column.

Configuration > System > Date and Time Format

▲ Time Zone

Current Time Zone: GMT

Time Zone List

> Mexico	Alaska	
> Mideast	Aleutian	
> Pacific	Arizona	
> US	Central	
> posix	East-Indiana	
> right	Eastern	
CET	Hawaii	
CST6CDT	Indiana-Starke	
Cuba	Michigan	
EET	Mountain	
EOT		

Submit

Expand the time zone list, as necessary, until a location with the appropriate time zone is visible. Select the desired location. Click **Submit**.

Setting the Date and Time Format

To set the Date/Time format, select Date/Time Format

Configuration > System > Date and Time Format

▼ Time Zone

▲ Date/Time Format

Time Format: ▼

Date Format: ▼

▼ Set Date/Time

▼ SNTP

Select the desired Time Format.
Select the desired Date Format.
Select Submit when done.

Setting the Date and Time

Select Set Date/Time.
Enter time and date or select "Now" button to update the current date and time.
Select Submit when done.

Configuration > System > Date and Time Format

▼ Time Zone

▼ Date/Time Format

▲ Set Date/Time

Time: 24 Hours (hh:mm:ss)

Date: (DD.MM.YYYY)

Enabling SNTP (Simple Network Time Protocol)

The library must have network access to an SNTP server.

- Click **SNTP**.

Configuration > System > Date and Time Format

▼ Time Zone

▼ Date/Time Format

▼ Set Date/Time

▲ **SNTP**

SNTP Enabled

SNTP Server:

- Click **SNTP Enabled**.
- Enter the SNTP server address.
- Click **Submit**.

Configuring Media Barcode Compatibility Checking

Configuration > System > Media Barcode Compatibility Check

- Barcode Media ID Restriction**
 When the box is checked, the Media Barcode Compatibility feature is enabled. This feature uses the media barcode identifier (the Media ID is the last two characters of the barcode) to verify the media is compatible with the tape drives installed.

NOTE: It is recommend to leave this option enabled (checked).

When **Barcode Media ID Restriction** is enabled, the library will only allow appropriate tape cartridges to be loaded into tape drives. The barcode media ID is the last two characters of the barcode. For example, an LTO-6 labeled cartridge will not be allowed to move into an LTO-4 tape drive. When disabled, the library will move any tape to any tape drive. If the cartridge is incompatible with the tape drive, the library will display a message.



NOTE

It is strongly recommended that all cartridges have barcode labels with the correct media ID, and that the Barcode Media ID Restriction is enabled.

License Key Handling

To add a license key, navigate to the **System > License Key Handling** screen.

Configuration > System > License Key Handling**▲ Add License Key**

License Key:

Add License**▼ License Key(s) in System****Add a license key**

- Enter license key. The license key needs to have a length of 15 characters
- Click **Add License**

**NOTE**

Once the license key is entered, the according information will appear in the list showing license keys in the system.

Network

Use the **Configuration > Network** screen to configure the library network settings.

Configuration > Network**▲ General Network Settings**

Host Name:

Domain Name:

Submit**Network Configuration**MAC Address: **00:0e:11:1e:e7:f2**Link Status: **Enabled**Link Speed: **1000 Mbit/s**Duplex: **Enabled**

Protocol:

Max. Link Speed:

▲ IPv4

Method:

Address:

Netmask:

Gateway:

DNS 1:

DNS 2:

▼ IPv6**Submit****Undo**

Configure or update the **Host Name** and **Domain Name**. The RMI URL is *<Host Name>.<Domain Name>*.

Select the internet protocol to use for the library.

Configure the settings for the selected internet protocol.

To have the library obtain an internet address from a DHCP server, select the DHCP or Stateless method.

Click **Submit**.

Network Management

From the **Configuration > Network Management** screen you can set or modify the following network management features:

- SNMP
- Event Notification (SMTP)
- Remote Logging (rsyslog)

Configuring SNMP

Use the **Configuration > Network Management > SNMP** screen to enable and configure SNMP (Simple Network Management Protocol), which allows applications to manage the device. The library supports both SNMP configuration and SNMP traps.

Configuration > Network Management > SNMP

SNMP Enabled: [Download MIB File](#)

Community Name:

Notification Level:

SNMP Targets

IP/Hostname	Port	Version	Community	Action
<input type="text"/>	162	SNMPv1	public	Edit Delete

The configuration options below are only needed when using SNMPv3.

Limit all library SNMP communication to SNMPv3:

SNMPv3 Security Level:

Authentication User Name:

Authentication Password:

NOTE: Needed for security levels authNoPriv and authPriv (8 -31 characters)

Authentication Protocol:

NOTE: Needed for security levels authNoPriv and authPriv

Privacy/Encryption Protocol:

NOTE: Needed for security level authPriv

[Submit](#) [Clear SNMPv3 Options](#)

- **SNMP Enabled** – When checked, the library can be managed by computers listed in the SNMP Target IP Addresses field.
- **Community Name** – A string used to match the SNMP management station and library. It must be set to the same name on both the management station and the library. The default community name is *public*.
- **SNMP Targets** – List of configured SNMP targets.

To add an SNMP target or edit information for an SNMP target:

- Click **Edit** for the appropriate SNMP target. When adding an SNMP target, click **Edit** next to a target without an IP/Hostname.
- Enter the target IP address or hostname
- Enter the port.
- Select the SNMP version.
- Enter the SNMP community string for the target.
- Click **Submit**.

To delete an SNMP target:

- Click **Delete** for the target to be deleted.

- Click **Submit**.

To clear SNMPv3 Options:

- Click **Clear SNMPv3 options**
- To confirm that you want to clear the SNMPv3 Options, click **Yes**

Configuring SMTP

From the **Configuration > Network Management > SMTP** screen you can enable SMTP (Simple Mail Transfer Protocol) functionality and configure e-mail notification of library events. The library must have network access to an SMTP server.

Configuration > Network Management > SMTP

▲ SMTP

SMTP Enabled:

Notification Level:

SMTP Server:

Security:

SMTP Port:

To Email Addresses (semicolon separated):

Mailer Name:

Email Subject:

Mailer Address:

Authentication Required:

Username:

Password:

NOTE: The Submit button will perform any changes made on the page and send a test email.

- **SMTP Enabled** – Check to enable SMTP. When checked, the remaining configurations are active.
- **Notification Level** – The types of events for which the library should send e-mail
 - **Inactive** – No events are sent.
 - **Critical** – Only critical events are sent.
 - **+ Warnings** – Only critical and warning events are sent.
 - **+ Configuration** – Only critical, warning, and configuration events are sent.
 - **+ Information** – All events are sent.
- **SMTP Server** – Hostname or IP address of the SMTP server
- **Security** – Security protocol for accessing the SMTP server
 - **None**
 - **SSL => SSL/TLS**
 - **TLS = STARTTLS**
- **SMTP Port** – SMTP server port. The default port for the selected protocol will be selected. You can choose one of the default ports or configure a custom port.
- **To Email Address** – The address to receive the reported events (for example firstname.lastname@example.com). Only one email address can be configured.
- **Mailer Name** – Name of the sender of the e-mail
- **Email Subject** – Subject line for the e-mail message
- **Mailer Address** – Return address to use for the e-mail message

- **Authentication Required** – When checked, a username and password are required to access the SMTP server.
- **Username** – User account for logging into the SMTP server when authentication is required
- **Password** – Password associated with the Username when authentication is required

Configuring Remote Logging

Use the **Configuration > Network Management > Remote Logging (rsyslog)** screen to enable and configure Remote Logging

Configuration > Network Management > Remote Logging (rsyslog)

▲ Remote Logging

Remote Logging Enabled:

Notification Level: Inactive ▼

Remote Logging Server:

Remote Logging Port: Custom ▼

Transport Protocol: UDP ▼

- **Remote Logging Enabled** – When checked, the library will start forwarding log messages in a selected IP Network
- **Notification Level** – With this field you can select the notification level
 - **Inactive** – No events are sent.
 - **Critical** – Only critical events are sent.
 - **+ Warnings** – Only critical and warning events are sent.
 - **+ Configuration** – Only critical, warning, and configuration events are sent.
 - **+ Information** – All events are sent.
- **Remote Logging Server** – Hostname or IP address of the Remote Logging server
- **Remote Logging Port** – Select between Default Remote Logging Port or Custom Port
- **Transport Protocol** – With this field you can select the Transport Protocol (UDP, TCP)

Configuring Tape Drives

From the **Configuration > Drives** screen you can see and modify drive configuration.

Configuration > Drives > Settings

▲ Drive: 1 S/N: ██████████ IBM LTO 9 HH FC Pwr: On

Firmware: █████ Manufacturer S/N: ██████████

Power On

Port A Configuration

Speed: Port Type:

Addressing Mode: Loop ID / ALPA:

Port B Configuration

Speed: Port Type:

Addressing Mode: Loop ID / ALPA:

- Drive number – Drives are numbered from the bottom of the library up beginning with one. The drive currently hosting the SCSI communication for the library is designated with (LUN).
- Serial Number – The serial number assigned to the tape drive by the library. This serial number is reported to host applications. The serial number cannot be modified.
- This is not the serial number assigned to the drive by the manufacturer; the serial number assigned by the manufacturer is shown in Manufacturer S/N.
- LTO generation
 - LTO 6 Ultrium Tape Drive
 - LTO 7 Ultrium Tape Drive
 - LTO 8 Ultrium Tape Drive
 - LTO 9 Ultrium Tape Drive
- Drive form factor
 - HH – half height
- Drive interface
 - FC – Fibre Channel
 - SAS – Serial Attached SCSI
- (Modified) – When present indicates that a setting has been changed. To apply the changes, click **Submit**. To reset all changed fields to their previously saved values, click **Undo**.
- **Pwr** – Indicates whether the drive is currently powered on or off.
- **Firmware** – The version of firmware currently installed on the drive.
- **Manufacturer S/N** – The serial number assigned to the drive when it was manufactured. Use this serial number when working with your Service.
- **Power On** – Checked when the drive is powered on.

**NOTE**

Always power off a tape drive before removing it from the library or moving it to a new location within the library.

- Port configuration (FC only) – Drive port configuration.
 - **Speed** – The currently selected speed. The default is Automatic.

- **Port Type**
 - **Automatic**
 - **Loop** – Enables selection of the Addressing Mode.
 - **Fabric**
- **Addressing Mode** – When Port Type is set to Loop, Addressing Mode can be set to **Soft**, **Hard**.
- **ALPA** – When Addressing Mode is set to Hard, you can choose an ALPA address from the drop down list.

To modify the configuration of one or more tape drives:

- Modify any of the configurable values.
- Click **Submit**.

Enabling or Disabling Mailslots

The **Configuration > Mailslot** screen lists each of the mailslots and shows whether each is enabled or disabled. To change the state, click the button for the mailslot and then click **Submit**. Slots not enabled as mailslots are available as storage slots.

Configuration > Mailslot

Mailslot Magazine	
Enabled	Disable

Submit

Configuring Library Partitions

The library has a flexible partitioning scheme with a few key constraints:

- Each partition must have at least one tape drive. One drive in each partition will host the library LUN for the partition.
- Mailslots must be enabled for the library before they can be allocated to a partition.

A partition does not need to have a mailslot. If a partition does not have a mailslot, the magazine must be accessed to import or export cartridges. Opening a magazine takes the library offline. Wizards guide you through the partition configuration process. The wizards are only accessible from the RMI.

- Use the Basic Partition Wizard to configure the number of barcode characters to report to the host application and whether to report them from the left or right end of the label.
- Use the Expert Partition Wizard to limit the number of slots reported to the host application.



CAUTION

The library will go offline while partitions are being configured. Ensure that all host operations are idle before running a partition wizard.

Using the Basic Partition Wizard

- Click **Configuration > Basic Wizard** to start the wizard.
- The **Information** screen displays the existing partitions, which will be deleted by the wizard.
- Click **Proceed** and then click **Next**.
- The **Create Partition Scheme** screen displays the number of slots, mailslots, tape drives, and maximum available partitions for the library.



NOTE

If you want to enable or disable the mailslots, **Cancel** out of the wizard and update the mailslot configuration before configuring partitioning.

- Select the number of barcode characters reported to the host application. This option provides interchange compatibility with libraries with more limited barcode reading capabilities. The maximum length is 16 and the default is 8. This configuration will apply to all partitions.



NOTE

The industry standard length for LTO barcode labels is eight characters. Barcode labels longer than eight characters might scan incorrectly, particularly if they are not high quality labels.

- Select whether to report the barcode characters from the left or right end of the barcode label to the host application when reporting fewer than the maximum number of characters. For example, when reporting only six characters of the barcode label 12345678, if alignment is left, the device will report 123456. If alignment is right, the device will report 345678. The default is left. Click **Next**.
- The **Finish Configuration** screen displays the proposed allocation of library resources into partitions.
 - To make any changes to the configuration, click **Back**.
 - To have the wizard configure the partition as shown, click **Finish**.
 - After the wizard reconfigures the partition, the library will come on line automatically.
 - To exit the wizard, click **Cancel** or **Exit**.



TIP

You can use the Expert Partition Wizard to adjust the allocation of resources after creating the partitions with the Basic Partition Wizard.

Using the Expert Partition Wizard

Click **Configuration > Expert Wizard** to start the wizard. The **Create Partition Scheme** screen lists the current partitions, if any, and the free resources. Use the wizard to configure one partition at a time.



NOTE

If you want to enable or disable the mailslots, **Cancel** out of the wizard and update the mailslot configuration before configuring partitioning.

- Select the number of barcode characters reported to the host application. This option provides interchange compatibility with libraries with more limited barcode reading capabilities. The maximum length is 16 and the default is 8. This configuration will apply to all partitions.



NOTE

The industry standard length for LTO barcode labels is eight characters. Barcode labels longer than eight characters might scan incorrectly, particularly if they are not high quality labels.

- Select whether to report the barcode characters from the left or right end of the barcode label to the host application when reporting fewer than the maximum number of characters. For example, when reporting

only six characters of the barcode label 12345678, if alignment is left, the device will report 123456. If alignment is right, the device will report 345678. The default is left. Click **Next**.

- In the **Assign Storage Slots** screen, use the >> and << buttons to remove/assign slots to the partition and then click **Next**.
- In the **Assign Mail Slots** screen, use the >> and << buttons to assign a mailslot to the partition and then click **Next**.
- Verify the partition configuration and then click **Finish**.
- After the wizard reconfigures the partition, the library will come on line automatically.

Configuring Encryption

The **Configuration > Encryption** page provides several options.



NOTE

The Encryption page is only available to the Security user account. When changing certain configuration options the library will go offline to hosts.

Configuration > Encryption

When changing certain configuration options the library will go offline to hosts. Only perform these config changes when it is acceptable for the library to go offline.

Set Default Encryption Mode for new Partitions

Set the default encryption mode for new Partitions. Will be used if a partition gets created:

Controlled by Backup Application ▼

Apply to all existing partitions

General Settings

Allow Administrator encryption configuration during Expert Partition Wizard

Note: Enabling this selection allows library administrators to enable and disable encryption on a per-partition basis, without needing further approval from the Security user.

Set Encryption Mode per Partition

New Partition_1: Controlled by Backup Application ▼

Submit

Set Default Encryption Mode for new Partitions by selecting the encryption mode from the dropdown box.

Click the **Apply to all exiting partitions** button to set the selected encryption mode for all exiting partitions. Click the **Submit** button to activate the encryption modes.

Clicking the checkbox in section **General Settings** will give the Administrator user account to enable and disable encryption during the use of the Expert Partition Wizard.

The **Set Encryption Mode per Partition** section allows you to select the encryption mode on a per-partition basis. Click the **Submit** button to activate the encryption modes.

KMIP Wizard

The library supports integration with encryption key management servers using the KMIP standard. The key management server will share encryption keys with the library.

With the Key Management Interoperability Protocol (KMIP) Wizard you can configure the use of KMIP key management servers with the library. Access to the wizard from the **Configuration > Encryption** menu is only available to the Security user and requires that the KMIP license has been purchased and added to the **Configuration > System > License Key Handling** screen.

**NOTE**

For additional information on configuring KMIP servers for use with the library, see your KMIP server documentation.

Before running the wizard, verify that:

- The library configuration is complete, including defining all library partitions.
- The KMIP server is available on the network and has been configured for use with this library.

Using the KMIP Wizard

- In the **Configuration** area, click **KMIP Wizard** in the **Configuration > Encryption** menu to start the wizard.
- The **Wizard Information** screen displays information about the wizard. If the library configuration is complete and the KMIP server is available on the network, click **Next**.
- The **Certificate Authority Information** screen displays prerequisites for using the KMIP certificate. When the prerequisites are met, click **Next**.
- The **Certificate Authority Certificate Entry** screen displays instructions for obtaining the certificate for the KMIP server. Follow the instructions to copy the certificate from the management console. Paste the certificate into the wizard and then click **Next**.
- The **Library Certificate Information** screen displays information about the next wizard steps. Click **Next**.
- The **KMIP Client Configuration** screen provides options for two types of server authentication.
 - If your KMIP server uses a client username and password for authentication, enter the username and password that were specified on the KMIP management console for the library.
 - If your KMIP server uses *only* certificate passing for authentication, select **Enable KMIP Certificate-only authentication**. Only select this option if you are using a KMIP server that requires it and you do not have a client username and password.

Click **Next**.

- The **Certificate Generation** screen displays the current library certificate, if one exists. To use the current certificate, select **Keep Current Certificate** and then click **Next**. To generate a new certificate, select **Generate New Certificate**. The wizard will generate and display a new library certificate. Click **Select Certificate** to copy the new certificate text and then click **Next**.
- If you selected **Generate New Certificate**, the **Sign Library Certificate** screen displays the new certificate for the library. Sign the new library certificate with the certificate authority as a client certificate, paste the new KMIP certificate in the box, and then click **Next**.
- In the **KMIP Server Configuration** screen, enter the IP address or fully-qualified hostname and port number for up to ten KMIP servers. To verify access to the KMIP servers, click **Connectivity Check**.
- The **Setup Summary** screen displays the settings that were collected by the wizard. Verify that the settings are correct and that there are no errors in the **Done** column. If you need to modify any settings or fix any issues, either click **Back** to reach the applicable screen or **Cancel** out of the wizard to fix the issues and return later. If the settings are correct and there are no errors, click **Finish**.

Configuring User Accounts

From the **Configuration > User Accounts** screen you can set or modify various user account properties.

User Account Settings

Navigate to **Configuration > Configure User Accounts > Configure User Accounts Settings** to set user Password Rules.

Configuration > User Accounts > User Accounts Settings

▲ Password Rules

Minimum Number Of Characters:	8 ▼
Minimum Number Of Upper Case Alphabetic Characters (A-Z):	1 ▼
Minimum Number Of Lower Case Alphabetic Characters (a-z):	1 ▼
Minimum Number Of Numeric Characters (0-9):	1 ▼
Minimum Number Of Special Characters (!@#%&*()_+~{} []\;:'" <>?,./):	0 ▼
Maximum Number Of Identical Consecutive Characters:	2 ▼
Maximum Number Of Failed Logins Before Password Is Locked:	3 ▼
Maximum Number Of Days Before Password Must Be Changed:	90 ▼
Minimum Number Of Days Before Password Can Be Changed:	Unlimited ▼
Number Of Password Changes Before An Old Password Can Be Used Again:	3 ▼
Maximum Number Of Failed TOTP Attempts before Login Is Locked:	10 ▼

- **Minimum Number of Characters**
Choose the minimum password length. The factory default value is 8. Possible range for this configuration option is from 8 to 20. The maximum password length is 20.
- **Minimum Number of Upper Case Alphabetic Characters (A-Z)**
Choose the minimum number of upper case alphabetic characters. The factory default value is 1. Possible range for this configuration option is from 0 to 3.
- **Minimum Number of Lower Case Alphabetic Characters (a-z)**
Choose the minimum number of lower case alphabetic characters. The factory default value is 1. Possible range for this configuration option is from 0 to 3.
- **Minimum Number of Numeric Characters (0-9)**
Choose the minimum number of numeric characters. The factory default value is 1. Possible range for this configuration option is from 0 to 3.
- **Minimum Number of Special Characters (!@#%&*()_+~{}|[]\;:'" <>?,./)**
Choose the minimum number of special characters. The factory default value is 0. Possible range for this configuration option is from 0 to 3.
- **Maximum Number of Identical Consecutive Characters**
Choose the maximum number of identical consecutive characters. The factory default value is 2. Possible range for this configuration option is from Unlimited to 3.
- **Maximum Number of Failed Logins Before account is Locked**
Choose the maximum number of failed logins before the account is locked. The factory default value is 3. Possible range for this configuration option is from Unlimited to 10.

**NOTE**

When an account is locked, the login cannot continue. The user must complete a valid login with an administrator account or needs to create a temporary password via the OCP. If the account cannot be unlocked, please contact Qualstar Support.

- **Maximum Number of Days Before Password Must Be Changed**
Choose the maximum number of days before the password must be changed. In case the password is expired, you will be forced to change the password during the login. The factory default value is 90. Possible range for this configuration option is from Unlimited to 365.
- **Number of Password Changes Before an Old Password Can Be Used Again**
Choose the amount of password changes to be done until a password can be used again. The factory default value is 3. Possible range for this configuration option is from 0 to 6.
- **Maximum Number of Failed TOTP Attempts before Login is Locked.**
Choose the maximum number of TOTP Attempts before the account is locked. The factory default value is 10. Possible range for this configuration option is 1-10.

Configuring Local User Accounts

Navigate to **Configuration > User Accounts > Local User Accounts Settings** to see the user accounts currently configured on the library.

By default, the library has four predefined user accounts: User, Administrator, Security and Service. When additional users are configured, the RMI login screens show the "additional users" along with the predefined users.

The table below lists the individual permissions for each predefined user role:

User Role	Permission
User	no rights at all, not allowed to add/edit/delete any user
Administrator	allowed to add/edit/delete User and Administrator role allowed to change Role Permissions
Security	allowed to add/edit/delete Security role allowed to change Role Permissions
Service	allowed to add/edit/delete Security role

By pressing the Add User button you can add up to 80 users to the Local User Account list. A dialog window will open and help you create the new user.

Configuration > User Accounts > Local User Accounts

NOTE: A maximum of 80 users can be added to the system.

▲ Local Users

Add User +

Actions ▼

Filter By Name

Name	User Role	Status	Last Activity
administrator	Administrator	Connected	19:21:16 27.04.2026
user	User	Disconnected	N/A

The added user will be prompted to set a new password at the first login

To Edit an existing User account, select the User that you want to edit and select the Actions dropdown list.

Configuration > User Accounts > Local User Accounts

NOTE: A maximum of 80 users can be added to the system.

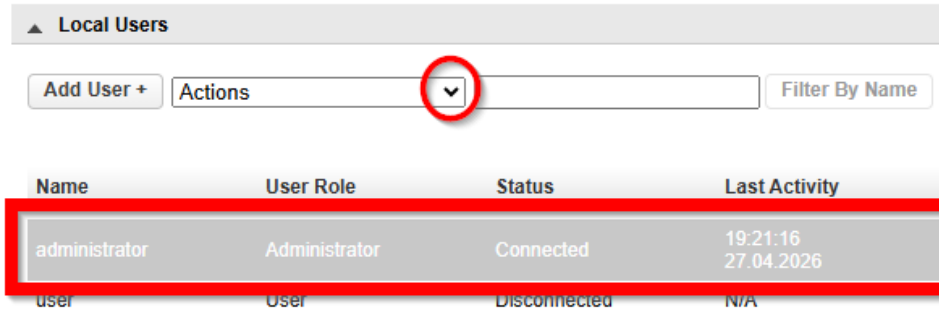

Name	User Role	Status	Last Activity
administrator	Administrator	Connected	19:21:16 27.04.2026
user	User	Disconnected	N/A

The Action dropdown list provides the following options.

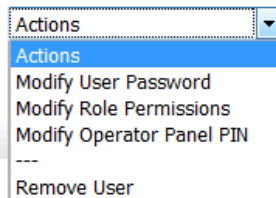

Modify User Password

Selecting this action will open a window where the User Name and User Password can be changed. Please note that the name for default local user (user, administrator, service, security) are not changeable.

Modify Role Permissions

A window appears that will allow you to configure Mailslot and/or Magazine access for the User Role.

Modify Operator Panel PIN

A window appears and helps you create a new OCP PIN for a specific User Account.

Remove User

This action is only active if user is selected. It is only valid for the "new users" which were previously added to the list. Default local user accounts cannot be removed from the list.

Configuring Multi-factor Authentication

Multi-factor authentication for users can be enabled/disabled in the "**Modify User Password**" window.

Notes:

- NTP must be active to set 2FA
- NTP cannot be disabled if there are active 2FA users.
- Any authenticator app that supports TOTP with SHA1 can be used (e.g.: Google Authenticator, Duo, Win Auth, etc.)
- Admins who want to configure 2FA for other users are obliged to have 2FA active themselves.

Enabling 2FA for the current logged in user will trigger a setup of 2FA directly on the active Session.

During this process the user can set up TOTP using the seed generated by the system or by providing a custom seed.

If these steps are successful, the TOTP will be set to active for that user:

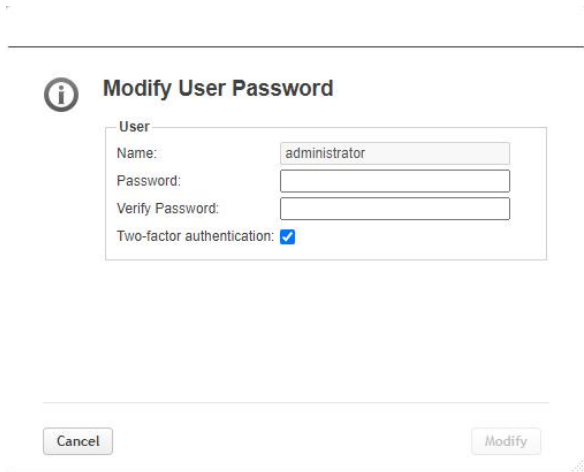

The screenshot shows a dialog box titled "Modify User Password" with an information icon. It contains a "User" section with the following fields: "Name:" with the value "administrator", "Password:", "Verify Password:", and "Two-factor authentication:" with a checked checkbox. At the bottom, there are "Cancel" and "Modify" buttons.

Selecting the Two-factor authentication checkbox will open a new window with a QR code.

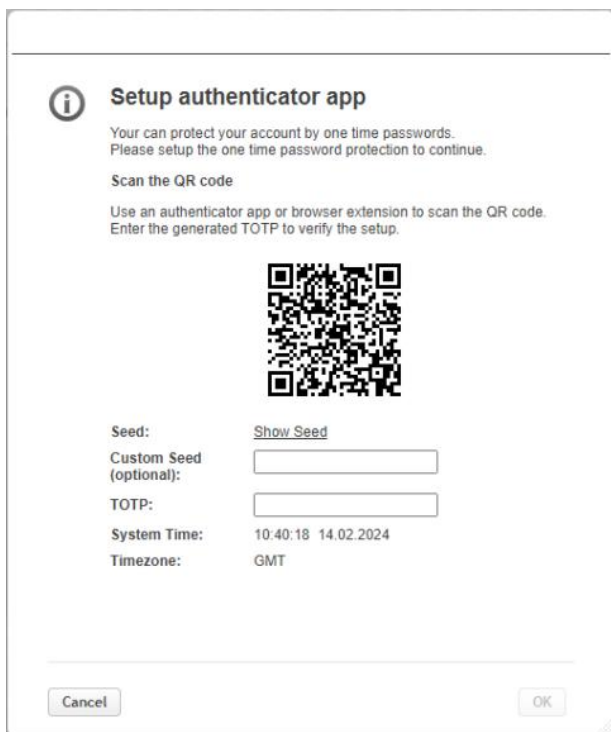

The screenshot shows a dialog box titled "Setup authenticator app" with an information icon. It contains the following text: "Your can protect your account by one time passwords. Please setup the one time password protection to continue." Below this is the heading "Scan the QR code" and the instruction "Use an authenticator app or browser extension to scan the QR code. Enter the generated TOTP to verify the setup." A QR code is displayed in the center. Below the QR code are the following fields: "Seed:" with a "Show Seed" link, "Custom Seed (optional):", "TOTP:", "System Time:" with the value "10:40:18 14.02.2024", and "Timezone:" with the value "GMT". At the bottom, there are "Cancel" and "OK" buttons.

This QR code can be scanned with an authenticator app to generate the TOTP (Time-based One-Time Password), or by manually entering the Seed into the authenticator app (Clicking "Show Seed" will display the unique key).

If a custom seed is being used, enter the custom seed in key in both the library window and the authenticator app.

If you Set 2FA for another user or a new user account, the user will be prompted to set up the TOTP (2FA) on their next valid login:

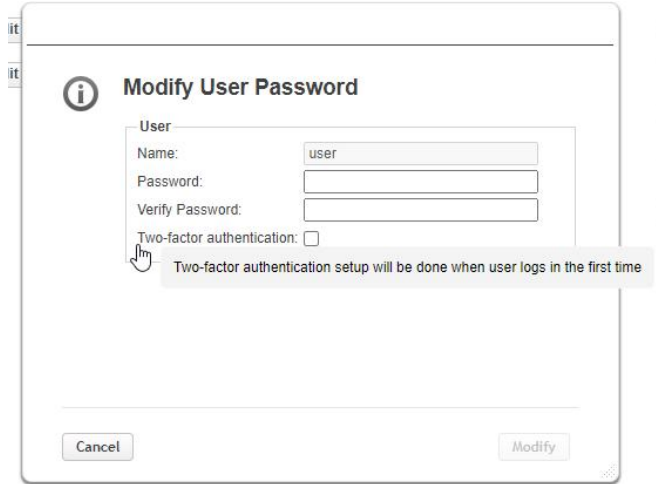

TOTP was set for another user will require that user to setup Two-step verification at his next login:

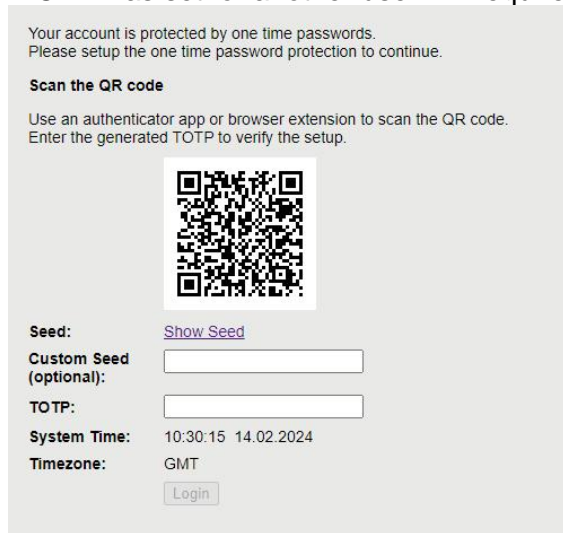

After successful setup of 2FA, TOTP will be required for each subsequent login:

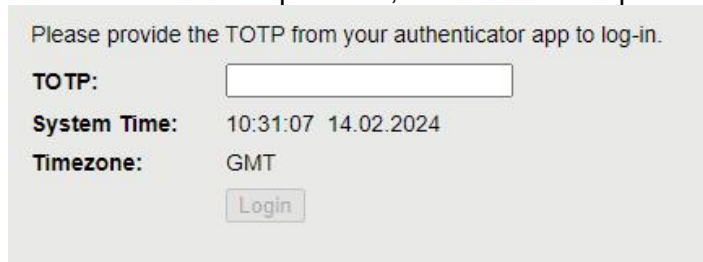

If TOTP gets locked, it will show a Recovery TOTP on the OCP to reset the TOTP settings for that user:

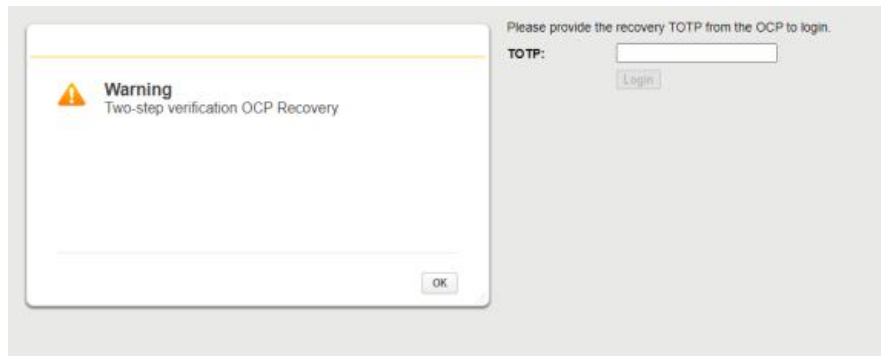

=> OCP:

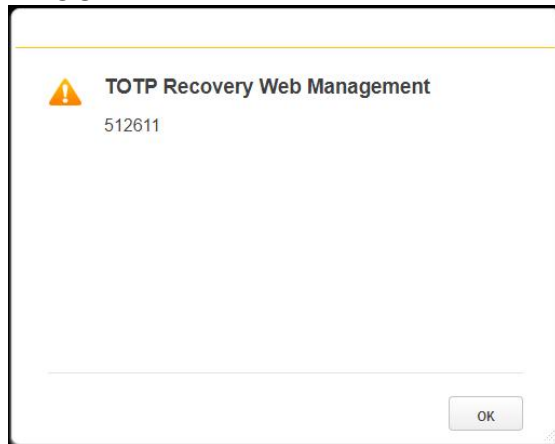

NOTE

The OCP recovery window is only displayed for a limited time. After recovering the account using the OCP recovery method the user is required to reset their Two-step verification again.

Configuring LDAP

Navigate to the **Configuration > User Accounts > LDAP** page to configure LDAP Servers to create user accounts that will be used to login to the library.

By default, the library has four predefined user accounts: User, Administrator, Security and Service. When LDAP servers are configured, the RMI login screens show the LDAP users along with the predefined users.

Each LDAP user is assigned to a role, based on the predefined user roles, and this role determines the access level for the LDAP user.



Using LDAP does not disable the predefined user accounts. For library security, ensure that the password for the predefined administrator user account is always set.



LDAP server configuration is dependent on the company's IT environment and security model. See your IT administrator for the settings for your environment. Before the wizard is used, you must know:

- IP address and port for the primary and backup LDAP servers
- User CN (Common Name) for the user who has access to the LDAP server
- User DN (Distinguished Name). This is the DN in which the User CN is located.
- Base DN. Parameters needed to search for potential library users in the LDAP server. For example, OU=Users,OU=RW,DC=libgroup,DC=local.
- Attribute Mapping, Username. For most Windows Active Directory environments, the **Username** field under **Attribute Mapping** should be set to **sAMAccountName**.
- If SSL is required for the LDAP server. This field is likely required for newer versions of LDAP servers.

- Navigate to the **Configuration > User Accounts > LDAP** page.
- If not already listed, add your LDAP servers.
 - In the **LDAP Servers** area click **Add Server**.

The RMI displays the **Add Server** dialog.

- Enter all of the requested LDAP configuration settings in the Primary Server area.

See your LDAP server documentation or local LDAP administrator for the preferred values for the various LDAP configuration settings, such as the port number and distinguished names.

- **Host** - IP address for the LDAP server
- **Port** - The default is 389 (636 with SSL). Port 3268 (3269 with SSL) when Base DN pointed to the global catalogue.
- **User CN** (Common Name) - The LDAP user of the person or group that is the library administrator. Many environments use the format "Surname, Name" or the email address for a group of library administrators.
- **User DN** - This is the DN where the User CN is included. For example: DC=Examplegroup,DC=local
- **Password** - LDAP password of the User CN. This might be the User CN's Windows password or an environment-specific password.
- **Use SSL** - If SSL is required by your organization, select **Use SSL** and then paste the appropriate CA certificate.

Enter the **Secondary/Backup Server** host address and port number.

Enter the **Distinguished Name** and **Attribute Mapping** parameters.

- **Base DN** - The LDAP parameters for the LDAP accounts for potential library users. For example: OU=Internal,OU=Users,OU=RW,DC=examplegroup,DC=local
- Click **Test Connection** to verify the configuration.
- When the library successfully connects to the LDAP server, click **OK**.
- In the **LDAP User** area, click **Add User**.

The RMI displays the **Add User** dialog.

- Click **Query LDAP Servers** to see a list of available users.
- Select the user name and then assign the user a role (User, Administrator, Security or Service).

Security user role can only assigned by another security user. The other roles can be assigned by an user having the administrator role. Click **OK**

LDAP server settings can be modified after the server was added. Selecting a server from the server list and choosing **Modify Server** from the LDAP Servers action menu, will open the **Modify Server** dialog.

Removing a server can be done by selecting the server which should be removed and choosing **Remove Server** from the LDAP Servers action menu. This action must be confirmed. The LDAP users that are related to the removed server are automatically removed with the server.

The user role of an LDAP user can be modified after the user has been added. This can be done by selecting the specific user and using the **Modify User** action from the LDAP User action menu.

Removing a user can be done by selecting the user which should be removed and choosing **Remove User** from the LDAP Users action menu. This action must be confirmed.

Configuring Kerberos

Navigate to **Configuration > User Accounts > Kerberos** to configure Kerberos Servers to create user accounts that will be used to login to the library.

By default, the library has four predefined user accounts: User, Administrator, Security and Service. When Kerberos servers are configured, the RMI login screens show the Kerberos users along with the predefined users.

Each Kerberos user is assigned to a role, based on the predefined user roles, and this role determines the access level for the Kerberos user.

**NOTE**

Using Kerberos does not disable the predefined user accounts. For library security, ensure that the password for the predefined administrator user account is always set.

**NOTE**

Kerberos server configuration is dependent on the company's IT environment and security model. See your IT administrator for the settings for your environment. Before adding a server, you will need to know:

- Realm
- Default Domain
- KDC (Key Distribution Center) address and port
- Admin Server address and port

Default Domain and Admin Server is not a required configuration option for Kerberos 5 servers.

- Navigate to the **Configuration > User Accounts > Kerberos** page.
- If not already listed, add your Kerberos servers.
 - In the **Kerberos Servers** area click **Add Server**.

The RMI displays the **Add Server** dialog.

- Enter all of the requested Kerberos configuration settings in dialog. See your Kerberos server documentation or local Kerberos administrator for the preferred values for the various Kerberos configuration settings.
 - **Realm** - This is your Kerberos realm, which is usually a domain name in upper case letters. For example, the machine foo.abc.com is in the ABC.COM Kerberos

- realm.
 - **Default Domain** - The default domain of the Kerberos server.
 - **KDC, Port** - The address and port of the key distribution center.
 - **Admin Server, Port** - The address and port of the admin server.
- Click **Test Connection** to verify the configuration.
- When the library successfully connects to the Kerberos server, click **OK**.
- In the **Kerberos Users** area, click **Add User**.

The RMI displays the **Add User** dialog.

- Enter all of the requested user settings in dialog.
 - **Principal** - Enter the name of the Kerberos Principal in this field. The Principal name consists of a number of components separated using the "/" separator.
 - **Realm** - This is your Kerberos realm. A drop down list offers the realms of the previously configured Kerberos servers.
 - **User Role** - Monitor, Superuser or Administrator. The other roles can be assigned by an user having the administrator role.
- Click **OK** to add the user.

Kerberos server settings can be modified after the server was added. Selecting a server from the server list and choose **Modify Server** from the Kerberos Servers action menu, opens the **Modify Server** dialog.

Removing a server can be done by selecting the server which should be removed and choosing **Remove Server** from the Kerberos Servers action menu. This action must be confirmed. The Kerberos users related to the removed server are automatically removed with the server.

The user role of a Kerberos user can be modified after the user has been added. This can be done by selecting the specific user and using the **Modify User** action from the Kerberos Users action menu.

Removing a user can be done by selecting the user which should be removed and choosing **Remove User** from the Kerberos Users action menu. This action must be confirmed.

3.2.7 Maintenance Menu

To access the library Maintenance options, navigate to **Maintenance**. The right pane of the screen will display the following options:

- Library Tests
- Logs and Traces
- Firmware Upgrades
- Download Drive Logs
- System Reboot
- Drive Reboot
- UID LED Control
- LTO-9 New Media Initialization Wizard

Library Tests

- System Test
- Slot to Slot Test
- Element to Element Test
- Position Test
- Wellness Test
- Robotic Test

System Test

The system test exercises overall library functionality by moving cartridges within the library.

- During each cycle the library will move a cartridge from a full slot to an empty drive and then return

it to its original slot. You can select the number of cycles for the test. If the test is cancelled, the library will return the cartridge to its original slot.

- The library will not move cleaning cartridges during the test.
- The test operates over the whole library and does not take into account partition configuration.
- During the test the library is off line.

Maintenance > Library Tests > System Test

NOTE: The System Test loads cartridges from slots into drives, then returns each cartridge to its original slot a user-specified number of times. The test requires at least one compatible cartridge for each generation of tape drive in the library. The tape drives must be empty before starting the test, and at least one slot needs to be full. For more information, see the online help.

Cycles:	<input type="text" value="Select ..."/>	Test Status Direction : Drive (1) => Slot (1.3) Cycles : 1 of 1 Status : Passed
Media:	<input type="text" value="Seating"/>	

To run the system test, navigate to the **Maintenance > Library Tests > System Test** screen, select the number of cycles and then click **Start Test**.

Slot to Slot Test

The slot to slot test, randomly exchanges cartridges between slots to verify that the library is operating correctly. At the end of the test the cartridges are NOT returned to their original slots.



CAUTION

The test can move cartridges between partitions.

Maintenance > Library Tests > Slot to Slot Test

NOTE: The Slot to Slot Test randomly exchanges cartridges between slots a user-specified number of times. The test requires at least one cartridge in any slot and at least one empty slot in the library. For more information, see the online help.

Cycles:	<input type="text" value="Select ..."/>	Test Status Direction : Cycles : of Status :

To run the slot to slot test, navigate to the **Maintenance > Library Tests > Slot to Slot Test** screen, select the number of cycles and click **Start Test**.

Element to Element Test

The element to element test moves a selected cartridge to a selected slot or tape drive, and then returns it to the original slot. You can select the number of cycles to move the selected cartridge to the destination location and back.

The element to element test is intended to show that the library is operating correctly.

Maintenance > Library Tests > Element to Element Test

NOTE: The Element to Element Test moves cartridges between two user-defined element locations a user-specified number of times. The test requires at least one cartridge. If moving a cartridge to or from a tape drive, the cartridge must be compatible with the generation of the tape drive. One of the selected element locations must be empty, and one of the selected element locations must be full, before starting the test. For more information, see the online help.

Filter On
All

Source Elements			Destination Elements		
Element	Barcode	Part.	Element	Status	Part.
Mailslot (1.1)	010034L3	N/A	Drive (1)	Gen. 9	N/A
Slot (1.2)	F00649L8	N/A	Slot (1.4)		N/A
Slot (1.3)	SJ057GEL9	N/A	Slot (1.5)		N/A
			Slot (1.6)		N/A
			Slot (1.7)		N/A
			Slot (1.8)		N/A

Selected Source:
Selected Destination:

Cycles:

Test Status
 Direction :
 Cycles : of
 Status :

To run the element test:

- Navigate to the **Maintenance > Library Tests > Element to Element Test** screen.
- Select a cartridge from the **Source Elements** list.
- To select from a subset of the cartridges:
 - Click **Filter On**.
 - Enter characters into the search box and then click **Search**.
- The **Source Elements** list is updated to only include cartridges with a barcode label including the search characters.
- Select a location from the **Destination Elements** list.
- Select the number of cycles.
- Click **Start Test**.

Position Test

The position test moves the robotic assembly vertically between two element locations. The test does not move cartridges. You can select the number of times to move the robotic assembly between two element positions.

The position test is intended to show that the vertical movement of the robotic assembly is operating correctly.

Maintenance > Library Tests > Position Test

NOTE: The Position Test moves the robotic assembly vertically between two element locations a user-specified number of times. The test does not move cartridges. For more information see the online help.

Filter On
All

Source Elements			Destination Elements		
Element	Barcode	Part.	Element	Barcode	Part.
Mailslot (1.1)	010034L3	N/A	Mailslot (1.1)	010034L3	N/A
Drive (1)		N/A	Drive (1)		N/A
Slot (1.2)	F00649L8	N/A	Slot (1.2)	F00649L8	N/A
Slot (1.3)	SJ057GEL9	N/A	Slot (1.3)	SJ057GEL9	N/A
Slot (1.4)		N/A	Slot (1.4)		N/A
Slot (1.5)		N/A	Slot (1.5)		N/A
Slot (1.6)		N/A	Slot (1.6)		N/A
Slot (1.7)		N/A	Slot (1.7)		N/A
Slot (1.8)		N/A	Slot (1.8)		N/A

Selected Source:

Selected Destination:

Cycles: Select ...
 Test Status
 Direction :
 Cycles : of
 Status :

To run the position test:

- Navigate to the **Maintenance > Library Tests > Position Test** screen.
- Select a source location from the **Source Elements** list.
- Select a destination location from the **Destination Elements** list.
- Select the number of cycles.
- Click **Start Test**.

Wellness Test

The wellness test performs a general health check of library functionality by running the following partial tests:

- Basic Hardware Review
- Robotics Initialization Test
- Barcode Scanning Test
- Move Media Test

Running the test requires at least one enabled and functional drive and one cartridge with a barcode label in each module.

- After the test has been started the **Stop Test** button is active. Clicking the button will abort the wellness test but not before the current partial test has been completed.
- The test operates over the whole library and does not take into account partition configuration.
- During the test the library is off line.

- The Info column notifies the user about the status and result of each partial test.

Maintenance > Library Tests > Wellness Test

NOTE: The Wellness Test checks various library operations and hardware components. The Wellness Test requires at least one enabled and functional drive in the Library stack and one cartridge with barcode label in each module. For more information, see the online help. For a quick test execution it is recommended to have one functional drive in each module and 8 compatible data cartridges in the corner slots of the same module.

Start Test Stop Test

Robotics initialization test in progress... 

Step	Info	Done
▼ Basic Hardware Review	Successful	
Robotics Initialization	Processing	
▼ Barcode Scanning Test	Not yet started	
▼ Move Media Test	Not yet started	

To run the Wellness test, navigate to the **Maintenance > Library Tests > Wellness Test** screen, and then click **Start Test**.



NOTE

For quickest test execution it is recommended to have one functional drive in each module and 8 compatible data cartridges in the corner slots of the same module.

Robotic Test

The robotic test exercises all robotic movements and sensors.

Maintenance > Library Tests > Robotic Test

Start Test

Test Status _____
Status _____

To run the robotic test, navigate to the **Maintenance > Library Tests > Robotic Test** screen, then click **Start Test**.

Logs and Traces

- View Logs
- Download Logs and Traces

View Logs

To view library log files, navigate to **Maintenance > Logs and Traces > View Logs**. Select the log that you want to view.

- Event Ticket Log – Records library errors and warning events

- Information Log – Records library information warnings
- Configuration Log – Records configuration changes

Maintenance > Logs and Traces > View Logs

Event Ticket Log

 Include closed tickets

Ticket-No	Time	Event	Description	State	Component	Component ID	Severity	Total (1)
1	23.04.2026 18:06:56	4010	Drive is not compatible with this Library	Resolved	Drive	1 (1)	WARNING	

The log entries are displayed in order of most recent to oldest. The log entries contain a date and time code, event code, severity, component identifier and event details. The format for the date and time is: *YY.MM.DD HH.MM.SS.ss*.

- *YY.MM.DD* – The date displayed as Year.Month.Day
- *HH.MM.SS.ss* – The time displayed as Hour.Minute.Second.Hundredths of a second

Download Logs and Traces



NOTE

Users and Administrators should download support tickets instead of log and trace files because the support ticket will have complete information about each library event and is easier to read. See “**Downloading Support Tickets**”.

Maintenance > Logs and Traces > Download Logs and Traces

NOTE: Creating Library Logs may take up to 10 minutes.

To download the library logs and trace files from the RMI, navigate to **Maintenance > Logs and Traces > Download Logs and Traces** and then click **Save**.

Firmware Upgrades

- System Firmware
- Drive Firmware
- Customization

System Firmware

The firmware version currently installed in the library is displayed in the library status area. You can update the library firmware from the **Maintenance > Firmware Upgrades > System Firmware** screen.

Maintenance > Firmware Upgrades > System Firmware

▲ Firmware

Currently Installed Library Firmware: **1.0.0-A000**

Please choose a *.fbi for uploading.

Firmware File: No file chosen

To update the library firmware, click **Choose File** and select the new firmware file.

Maintenance > Firmware Upgrades > System Firmware

▲ Firmware

Currently Installed Library Firmware: **1.0.0-A000**

Please choose a *.fbi for uploading.

Firmware File: 

After selecting the firmware file, select Upload to update the firmware.

When you update library firmware, the library will also update the firmware of the expansion modules to a compatible version.

Drive Firmware

Drive firmware can only be updated from the RMI. Drives will only accept appropriate firmware.

Maintenance > Firmware Upgrades > Drive Firmware

▲ IBM L1017 HH - SAS

<input type="checkbox"/>	Drive	Type	Firmware	Serial	Partition
<input checked="" type="checkbox"/>	1	HH - SAS	1.0.0	XXXXXXXXXX	1

Image File: 

To update the drive firmware:

- Navigate to the **Maintenance > Software Upgrades > Drive Firmware** screen.
- Select the tape drive.
- Click **Choose File**, and then select the file from the local computer.
- Click **Submit**.

Download Drive Logs

To obtain the drive logs, navigate to Maintenance > Download Drive Logs.

Maintenance > Download Drive Logs

NOTE: Creating a Support Ticket may take up to 10 minutes.

▲ Drive Logs

Regular Dump ▼

	Drive	Type	Firmware	Serial	Partition
<input checked="" type="checkbox"/>	1	IBM - LTO7 - HH - SAS	Q3A1	11EE7F2001	1

- Select the tape drive.
- Select Regular Dump
- Select **Save**

System Reboot

To reboot the library, navigate to the **Maintenance > System Reboot** page and click **Reboot**.

Drive Reboot

To reboot the tape drive, navigate to **Maintenance > Drive Reboot**.

- Select the Drive.
- Select **Submit**.

UID LED Control

The UID (Unit Identification) LED refers to blue LEDs on the tape library that assist users and service personnel identify components that require attention.

Maintenance > UID LED Control

NOTE: UID LEDs are intended to assist users or service personnel in determining which component needs attention. This page allows you to control the UID LED for specific components.

▲ **Component Drive**

No drive present supporting UID LED control

▲ **Component Controller**

<input type="checkbox"/> Select All	Type
<input type="checkbox"/>	Controller

Switch LEDs On

Switch LEDs Off

To select and switch on UID LEDs, navigate to the **Maintenance > UID LED Control**.

- Expand the **Component Controller** list, if necessary, by clicking the down arrow on the left side.
- Select the component where you want to switch on the UID LED.
- Click the **Switch LEDs On** button

Repeat the procedure to switch off the UID LED.

LTO-9 New Media Initialization Wizard

New LTO-9 media cartridges require a one-time initialization prior to read/write operations. Initialization of the media will optimize data placement on each LTO-9 cartridge. The initialization is only required prior to the first use of an LTO-9 cartridge. Most tapes should be initialized in less than 30 minutes, however, in some cases it can take up to 2 hours.

An LTO-9 tape drive will automatically perform the initialization when needed. However, this may result in timeout errors from host systems. To assist you with this potential issue, you can use the library's LTO-9 New Media Initialization Wizard to perform the initialization without the need of the host system.

The LTO-9 New Media Initialization Wizard will guide you through an automated process to load a selection of uninitialized LTO-9 media into the LTO-9 tape drive to complete the initialization process.

- Navigate to the **Maintenance > LTO-9 New Media Initialization Wizard**.
- Click **Start LTO-9 New Media Initialization Wizard**.
- Click **Next** on the **Information** Screen.
- Select the cartridge(s) you want to initialize and click the right arrow. If all the cartridges need to be initialized, click **Select All**, then click the right arrow.
- This will place the cartridges in the section to the right titled **Selected Cartridges**.
- Click **Next**.
- Select the drive to be used for initializing the media and click the right arrow. This will place the drive in the section to the right titled **Selected Drives**.
- Click **Next**.
- Click **Finish** to complete the wizard and begin the media initialization process. The wizard screen will show the progress as the process completes. If you click **Exit**, you will leave the wizard, but the process will continue and updates will be displayed on the **Maintenance >**

LTO-9 New Media Initialization Wizard page.**NOTE**

The library and drive will report an offline status to the host system during the initialization process.

3.2.8 Operation Menu

To access the operation features of the library, select Operation on the Home screen. The right pane of the Operation Menu has the following options:

- Move Media
- Open Mailslot
- Open Magazine
- Clean Drive
- Rescan Inventory
- Force Drive Media Eject

Move Media

From the **Operation > Move Media** screen you can move a tape cartridge from a source element to an available destination element.

Operation > Move Media

Barcode Filter On

Search

Source Elements			Destination Elements		
Element	Barcode	Part.	Element	Status	Part.
Mailslot (1.1)	010034L3	N/A	Drive (1)	Gen. 9	N/A
Slot (1.2)	F00649L8	N/A	Slot (1.4)		N/A
Slot (1.3)	SJ057GEL9	N/A	Slot (1.5)		N/A
			Slot (1.6)		N/A
			Slot (1.7)		N/A
			Slot (1.8)		N/A

Move Source:
to Destination:

- **Source Elements** – Tape drives, enabled mailslots, and storage slots that contain a tape cartridge
 - **Destination Elements** – Tape drives, enabled mailslots, and storage slots that do not contain a tape cartridge
- The tape drive is listed at the top of each element list
- Slots are listed in the order of the slot numbers. Slots are numbered *m.s*, where *m* is the module number and *s* is the slot within the module.

Open Mailslot

Use this option to see the status and unlock the library's mailslot

Operation > Open Mailslot

Mailslot	
Closed	Open

To open a mailslot, click **Open**. The library will release the lock. You can then pull the mailslot open.



NOTE

The mailslot will relock after 30 seconds.

The mailslot must be enabled before it can be opened.



WARNING

Hazardous moving parts exist inside this product. Do not insert tools or any portion of your body into the interior of the library while the mailslot is pulled out.

Open Magazine

Use this option to see the status and unlock any magazine in the library.

Operation > Open Magazine

NOTE: Only one magazine is allowed to be removed at a time.

Left		Right	
Closed	Open	Closed	Open

To unlock a magazine, click **Open** for the magazine. The library will release the lock. You can then pull the magazine out of the library to access the storage slots.



NOTE

- Opening a magazine will take the library off-line.
- The magazines will relock after 30 seconds.

Clean Drive

From the **Operation > Clean Drive** screen you can initiate a drive cleaning operation.

Operation > Clean Drive

Source Elements				Destination Elements		
Element	Barcode	Part.	Use #	Element	Status	Part.
Slot (1.4)	CLNU73L1	N/A	N/A	Drive (1)		N/A

Move Source:

to Destination:

Submit

- Select a cleaning cartridge from the **Source Elements** list. The library uses the barcode label to identify cleaning cartridges.
- If no cleaning cartridges are available, load one into a mailslot or magazine slot.
- Select the tape drive to be cleaned from the **Destination Elements** list.
- Tape drives currently containing a cartridge are not listed. To clean a tape drive not listed, unload the cartridge out of the drive.
- Click **Submit**

Rescan Inventory

To have the library rescan its inventory, navigate to the **Operation > Rescan** screen and click **Rescan**. The library will rescan and be unavailable to perform other operations until the rescan is completed.

Operation > Rescan Inventory

NOTE: Rescan inventory can take several minutes to complete.

Rescan

Force Drive Media Eject

The force drive media eject operation attempts to force the tape drive to eject the cartridge and place it into an open slot. Access to this feature requires the administrator password.

Before performing this option, it is recommended that you attempt to eject the tape using the backup software or the standard library move media operation. While a drive is being force ejected, a window indicating the process is ongoing should appear. No operations will be available until the force eject completes.



NOTE If the drive has difficulty ejecting the cartridge, the media is possibly bad or damaged.

Operation > Force Drive Media Eject

Barcode Filter On

Search

Source Elements			Destination Elements		
Element	Barcode	Part.	Element	Status	Part.
Drive (1)	SJ057GEL9	N/A	Slot (1.3)		N/A
			Slot (1.5)		N/A
			Slot (1.6)		N/A
			Slot (1.7)		N/A
			Slot (1.8)		N/A

Move Source:
to Destination:

- Navigate to the **Operation > Force Drive Media Eject** screen.
- Select the drive in the **Source Elements** list.
- Select the destination in the **Destination Elements** list.
- Click **Submit**.

3.2.9 Status

To access the status features of the library, select Status on the Home screen. The right pane of the Status Menu has the following options:

- Library Status
- Cartridge Inventory
- Partition Map
- Drive Status
- Network Status
- Security

Library Status

Library Information and status is displayed on the **Status > Library Status** page.

Status > Library Status

▲ Library Information			
Vendor:	BDT	Product ID:	MULTISTAK
Serial Number:	DEC3411077FS		
Base Firmware Revision:	1.0.0-0088	Base Controller Revision:	B000
Robotic Hardware Revision:	0	Robotic Firmware Revision:	4.28
Barcode Reader Hardware Revision:	SE-625	Barcode Reader Firmware Revision:	PAAAMC00-002-N09D0
▲ Library Status			
Library Status:	Idle	Total Power On Time:	11d 23h 21m
Cartridge in Transport:	None	Odometer:	0
Left Magazine Status:	Closed	Right Magazine Status:	Closed
Mailslot Status:	Disabled - mailslot cannot be opened.	Shipping Lock:	Unlocked

Refresh

Library information

- Vendor
- Serial Number – Library serial number
- Base Firmware Revision – Version of the currently installed library firmware
- Robotic Hardware Revision
- Barcode Reader Hardware Revision
- Product ID
- Base Controller Revision
- Robotic Firmware Revision – Version of the currently installed robotic assembly firmware. The robotic assembly firmware is bundled and installed with the library firmware.
- Barcode Reader Firmware Revision – Version of the currently installed barcode reader firmware. The barcode reader firmware is bundled and installed with the library firmware.

Library Status

- Library Status
- Idle – The library is ready to perform an action.
- Moving – The library is moving a cartridge.
- Scanning – The library is performing an inventory of cartridges.
- Offline – The library has been taken offline.
- Total Power On Time – Total time that the Base Module has been powered on.
- Cartridge in Transport – When applicable, displays the barcode label of the cartridge currently in the robotic assembly
- Odometer – Robotic assembly move count
- Left Magazine Status
- Right Magazine Status
- Mailslot Status
- Shipping Lock Status

Cartridge Inventory

The cartridge inventory screen displays each of the slots and tape drives in the library. It provides information about the cartridge located in the element.

Graphical View

The inventory graphical view displays each of the elements with information about the cartridge stored in the element.

Unused slots, which are not available for move operations, are greyed out and marked with a cross.

Status > Cartridge Inventory > Graphical View

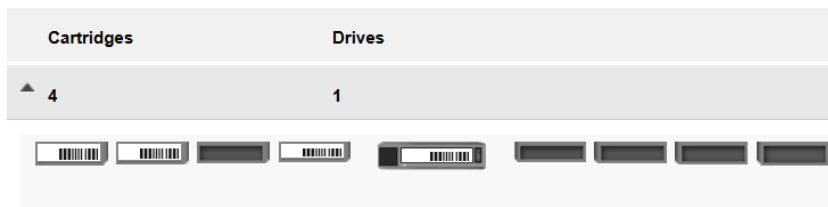

Moving the mouse over drive or cartridge will display additional information:

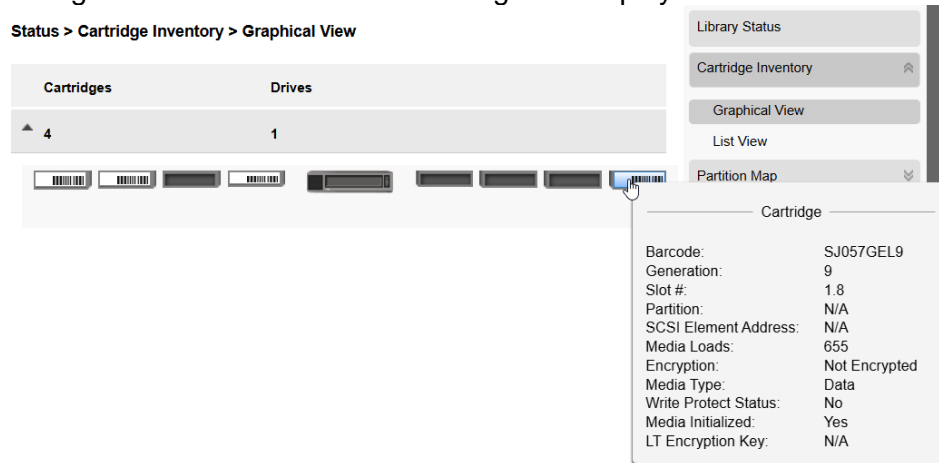

- **Drive** – LTO generation of drive and format (Full Height or Half Height)
- **Drive #** - The drive number
- **Serial #** - Serial number of the drive
- **Slot #** – The slot number
- **Barcode** – Barcode data on label
- **Generation** – LTO generation of cartridge
- **Partition** – The partition number
- **Media Loads** – The number of media loads
- **Encryption** – Indicates whether data on this media is encrypted or not encrypted
- **Media Type** – Indicates whether this media is a data or a cleaning cartridge

Warning and/or error states for a specific drive or cartridge are indicated with icons.

Status > Cartridge Inventory > Graphical View



List View

Cartridges stored in unused slots, which are not available for move operations, are greyed out and are not assigned to any partition

Status > Cartridge Inventory > List View

Slot #	Barcode	Full	Gen.	Partition
1.1	010034L3	X	3	N/A
1.2	F00649L8	X	8	N/A
1.3				
1.4	CLNU73L1	X	N/A	N/A
1.5				
1.6				
1.7				
1.8				
D (1)	SJ057GEL9	X	9	N/A

In the Inventory List you can see:

- **Slot #** – The slot number in the form <module>.<slot>, where module is the module number and slot is the slot number
- **Barcode** – Barcode label
- **Full** – X if the element is occupied
- **Gen** – LTO generation of the cartridge
- **Partition** – The partition number
-

Filtering by Barcode Label

To filter the list based on barcode label, enter characters in the filter box and then click **Search**.

- Click **Filter On**.
- Enter the characters into the search box and then click **Search**.
- The characters can be anywhere in the barcode label. The search characters are not case sensitive. There are no wildcards.

To disable filtering, click **Filter Off**.

Listing Just Drives or Cartridges

To limit the list to tape drives, click **Drives**.

To limit the list to cartridges, click **Cartridges**.

Partition Map

To see the elements organized by logical library or partition, navigate to Status > Partition Map.

List View

Cartridges stored in unused slots, which are not available for move operations, are greyed out and are not assigned to any partition

Status > Partition Map > Inventory List (Partition View)

Drives		Cartridges		Group Off	
Filter On					

Part.	Slot #	Barcode	Full	Gen.	Pos.
▲ 1	Partition S/N: DE64011238_LL01		Name: New Partition_1		
	(1001)	1.1			
	(1002)	1.2			
	(1003)	1.3			
	(1004)	1.4			
	(1005)	1.5			
	(1006)	1.6			
	(1007)	1.7			
	(1008)	1.8			

In the Inventory List you can see:

- **Partition** – The partition number
- **Slot #** – The slot number in the form <module>.<slot>, where module is the module number and slot is the slot number
- **Barcode** – Barcode label
- **Full** – X if the element is occupied
- **Gen** – LTO generation of the cartridge
-

Filtering by Barcode Label

To filter the list based on barcode label, enter characters in the filter box and then click **Search**.

- Click **Filter On**.
- Enter the characters into the search box and then click **Search**.
- The characters can be anywhere in the barcode label. The search characters are not case sensitive. There are no wildcards.

To disable filtering, click **Filter Off**.

Listing Just Drives or Cartridges

To limit the list to tape drives, click **Drives**.

To limit the list to cartridges, click **Cartridges**.

Viewing Elements by Group

When the list is grouped, you can expand or contract the list for each group by clicking the triangle next to the number in the first column. Grouping is enabled by default.

To disable grouping, click **Group Off**.

To enable grouping, click **Group On**.

Graphical View

To see the elements organized by logical library or partition navigate to Status > Partition Map > Graphical View.

Status > Partition Map > Graphical View

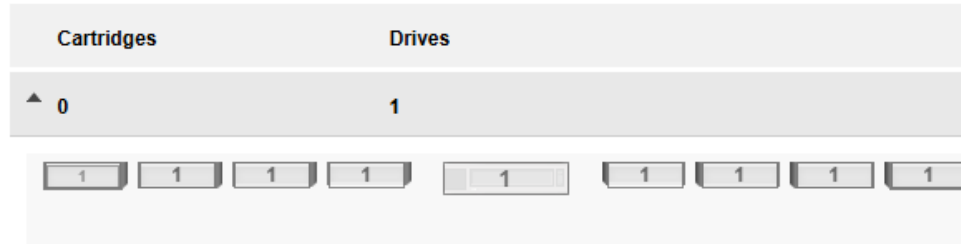

The graphical view of the partition map displays the partition number for every magazine. Magazine #1, which can be configured as a mailslot magazine, displays single slots. When they are configured as mailslots, the slot number gets a leading 'M'.

Moving the mouse over a partition layer will display additional information:

Status > Partition Map > Graphical View

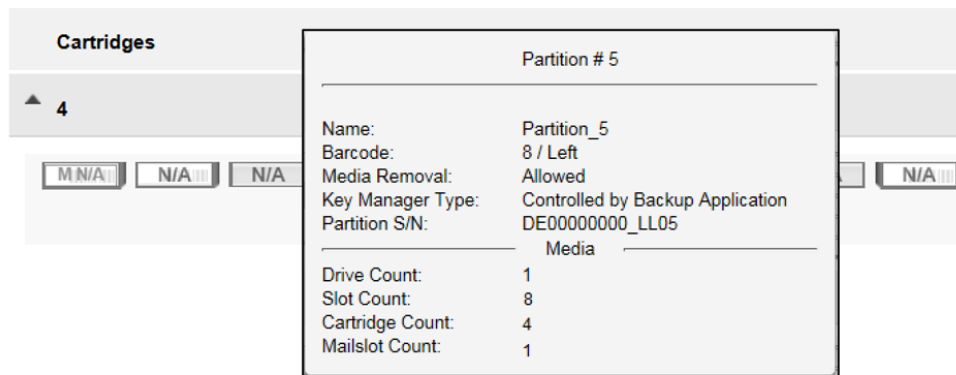

- **Name** – Partition name
- **Barcode** – Barcode orientation
- **Media Removal** – Indicates whether media removal is allowed or prevented by the host
- **Key Manager Type** – Encryption type
- **Partition S/N** – Serial number of the partition
- **Drive Count** – Number of drives in this partition
- **Slot Count** – Number of slots in this partition
- **Media Count** – Number of cartridges in this partition
- **Mailslot Count** – Number of mailslots in this partition

Moving the mouse over a drive will display additional information.

Status > Partition Map > Graphical View

Drive 1	LTO 7 / HH
Serial #:	000000006F
Partition:	3
Cartridge	
Barcode:	TC070ML5
Generation:	5
Partition:	3
Media Loads:	123
Encryption:	Not Encrypted
Media Type:	Data

- **Drive** – LTO generation of drive and format (Full Height or Half Height)
- **Drive #** - The drive number
- **Serial #** - Serial number of the drive
- **Partition** – The partition number

If a cartridge is loaded in the drive additional information about the cartridge is displayed.

- **Barcode** – Barcode data on label
- **Generation** – LTO generation of cartridge
- **Partition** – The partition number
- **Media Loads** – Number of loads
- **Encryption** – Encryption status
- **Media Type** – Data cartridge, Cleaning Cartridge

Configuration Status

To see the configuration of a partition, navigate to Status > Partition Map > Configuration Status. The configuration status will display the following information:

Status > Partition Map > Configuration Status

▲ Partition Number: 1 Partition Name: New Partition_1

Partition Number:	1
Partition Name:	New Partition_1
Partition S/N:	DE64011238_LL01
Partition WWide Node:	5000E111EE7F2004
Number of Drives:	▼ 1
Number of Slots:	8
Number of Mailslots:	0
Barcode Label Length Rep. to Host:	8
Barcode Label Alignment Rep. to Host:	Left
Auto Clean:	Disabled
Key Manager Type:	Controlled by Backup Application
Active Control Path Drive:	Drive 1 (LTO7 SAS)
LTO7+ Multi-initiator SCSI Conflict Detection:	Disabled

Refresh
Collapse All

- **Partition Number** – The partition number
- **Partition Name** – The partition name
- **Partition S/N** – The partition serial number
- **Number of Drives** – Number of drives in this partition
- **Number of Slots** – Number of slots in this partition
- **Number of Mailslots** – Number of mailslots in this partition
- **Barcode Label Length Rep. to Host** – Barcode length reported to the host
- **Barcode Label Alignment Rep. to Host** – Barcode alignment reported to the host
- **Auto Clean** – Indicates whether automatic cleaning of drives is enabled or disabled
- **Key Manager Type** – Encryption type
- **Active Control Path Drive** – LUN drive for this partition
- **LTO7 Multi-initiator SCSI Conflict Detection** – Indicates whether Multi-initiator Conflict Detection is enabled or disabled

Drive Status

To see the configuration and status of the tape drive, navigate to Status > Drive Status.

Status > Drive Status

▲ 1	S/N: ██████████	██████████	✓	Empty	On
-----	-----------------	------------	---	-------	----

Vendor:	██████████	Personality:	00 00
Firmware:	██████████	Manufacturer S/N:	██████████
Powered:	On	WWNN:	5000E111 EE7F2001
Temperature:	32 °C	Partition:	1 (Library LUN)
Encryption:	Controlled by Backup Application	Cartridge:	N/A
IP Address:	N/A	Media Removal:	Allowed
Module Loc:	1	Data Compression:	Enabled
Cooling Fan Status:	Active	Product ID:	ULTRIUM- HH7
SCSI Element Addr.:	1		

Port A Status (WWPN: 5000E111EE7F2002)

Interface:	Not Connected	Speed:	N/A
------------	---------------	--------	-----

Port B Status (WWPN: 5000E111EE7F2003)

Interface:	Not Connected	Speed:	N/A
------------	---------------	--------	-----

Refresh	Collapse All
---------	--------------

Network Status

To see the configuration and status of the network, navigate to Status > Network Status.

Status > Network Status

Host Name: TL-1EE7F2

Domain Name: qualstar.com

▲ General Network Settings

MAC Address: 00:0c:11:1e7f:7f:02 Link Status: Enabled
 Link Speed: 1000 Mbit/s Duplex: Enabled
 Protocol: IPv4

▲ IPv4

DHCP: Enabled
 Address: 192.168.1.100 Netmask: 255.255.255.0
 Gateway: 192.168.1.1
 DNS 1: 192.168.1.1 DNS 2:

- **Host Name** – Library hostname
- **Domain Name**
- **Protocol** – IPV4 or IPv6
- **MAC Address** – A unique identifier for the library controller network interface
- **Link Status** – Enabled or disabled
- **Link Speed** – Speed of the Ethernet connection to the library
- **Duplex** – Enabled or disabled
- IPv4 settings
- **DHCP** – When Enabled, the library requests an IP address from a DHCP server each time the library is powered on.
- **Address** – IP address in use by the library. If DHCP is enabled, this address was obtained from the DHCP server. When DHCP is not enabled, the address was configured.
- **Netmask** – The network mask of the library controller used when DHCP is not enabled.
- **Gateway** – The gateway used when DHCP is not enabled.
- **DNS 1**
- **DNS 2**
- IPv6 settings
- **Stateless Addressing** – When Enabled, the device will generate an address for itself based on the routing information obtained from a router advertisement and the MAC address. The device can manage up to five global addresses at the same time, which can be assigned from different routers.
- **Static Addressing** – When Enabled, the library will use a statically-configured address.
- **Static Assigned Address** – The IPv6 address when Static Addressing Enabled is On.

Security Status

To view the encryption settings of the library navigate to Status > Security.

Status > Security

▲ Security Encryption Status

KMIP: Disabled, Unlicensed

▲ Partition Encryption Status

▲ Partitions

Partition Number:	Partition Name and S/N:	Encryption Configuration:
1	Row Partition_1, DECRYPTED_CLUSTER	Controlled by Backup Application

▲ Drive Encryption Status

Drive	Encryption	Partition No.
Drive 1	Controlled by Backup Application	1

Refresh

- Security Encryption Status - Displays KMIP information.
- Partition Encryption Status - Displays the encryption configuration for the library.
- Drive Encryption Status – Displays the encryption status for the drive.

4 Servicing the Library

4.1 Possible Tools Needed

- #2 Phillips Screwdriver – securing or removing the round-hole rack adapter bracket, securing retention inserts in square-hole rack
- Small Flat Head or Torx Screwdriver – retracting the locking screen when moving a library cover, using the magazine manual release
- T10 Torx Screwdriver – removing drive bay covers
- Small Flat Head Screwdriver – removing a magazine access door
- Clip Nut Installation Tool – inserting or removing clip nuts in square-hole racks while installing or removing rack rails

4.2 Replacing a Tape Drive

**WARNING**

Read all troubleshooting documentation and procedures before proceeding with replacement of drive. Hazardous moving parts exist inside this product. Do not insert tools or any portion of your body into the drive bay openings.

Removing a Tape Drive

- Make sure the tape cartridge has been removed from the tape drive. Use the operator control panel (OCP) or the remote management interface (RMI) to move the cartridge to a storage slot or mailslot.
- Verify that all backup operations are stopped before removing the drive.
- Use the OCP or RMI to power off the tape drive.
- Verify that the LED on the back of the tape drive assembly is off.
- Disconnect the FC or SAS cable from the drive.
- Loosen the blue captive thumbscrews on the tape drive and pull straight back on the tape drive handle. Make sure to support the bottom of the drive when sliding the drive out of the library.

Installing a Tape Drive

- Align and slowly insert the new tape drive into the drive bay while supporting the bottom of the drive assembly. The tape drive should be flush with the back panel of the device.
- Tighten the captive thumbscrews with your fingers until the tape drive is secure.
- Reconnect the FC or SAS cable to the tape drive.
- Use the OCP or RMI to power on the tape drive, if necessary.
- Verify that the library recognizes the new drive.

4.3 Replacing a Controller Board

**CAUTION**

- Parts can be damaged by electrostatic discharge. Keep parts in electrostatic containers until needed. Ensure you are properly grounded when touching static sensitive components.
- You must power off the library to replace the Controller.

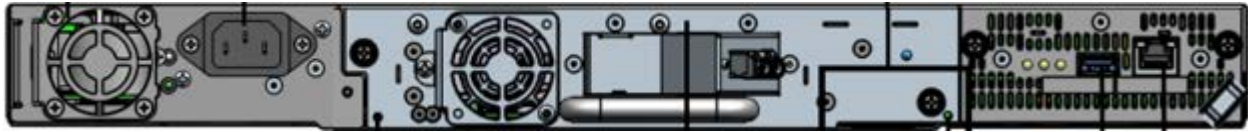

Preparing to replace the Controller Board

The library configuration settings are saved on the library chassis and will be restored automatically when the controller is replaced. However, it is recommended to save the configuration settings before removing the controller board. See "**Saving the Library Configuration to a File**" for instructions on saving configuration settings to a file or USB flash drive via the OCP or RMI.

Removing a Controller Board

- Power off the library.
- Unplug the AC power cord from the library.
- Disconnect the ethernet cable.
- Remove the USB device, if necessary.
- Loosen the two blue captive thumbscrews on the controller.
- Slowly pull on the loosened thumbscrews and slide the controller from the library.

Installing a Controller Board

- Position the new controller board on the alignment rails.
- Slide the controller board into the library until it is flush with the back of the library.
- Hand tighten the two blue captive thumbscrews.
- Reconnect the ethernet cable.
- Reinstall the USB device, if necessary.
- Plug in the AC power cord to the library.
- Power on the library.

Verifying the Controller Board Installation

- Check the library firmware version.
- Update the firmware from the **RMI Maintenance > Firmware Upgrades > System Firmware** screen, if necessary.
- Restore the previous configuration settings by restoring them from a saved file.
- Resume the host applications.

4.4 Installation problems

Problems encountered during the installation of the library are usually caused by cabling issues, application software configuration errors, or an incorrectly configured operating system. If the host application software is not communicating with the library after installation, check the following:

4.4.1 Cabling

Check that all cables to the Q8, including power, SAS and/or Fibre Channel, as well as Ethernet and USB (if present) are properly seated in their respective sockets at both ends, and that the Q8 is powered on. If so, and the host is still not communicating successfully with the library, then the cables themselves may need to be checked. If spare cables are available, this can be achieved by replacing one cable at a time and assessing whether the problem is cured as a result. Note that power may be left on while exchanging any of the data cables, as their removal and replacement will not cause damage to the library.

4.4.2 Compatibility

Ensure that the library is compatible with the backup application you plan to use. For a list of compatible application software, check with your backup application vendor.

4.4.3 Backup application installation

Refer to the documentation included with your backup application for instructions on how to verify proper installation. Some backup software packages require an additional module to communicate with the library media changer.

4.4.4 Device driver installation

Make sure that the proper device driver, if applicable, is installed for the library. Contact your support representative for more information



NOTE

- Many backup applications use their own drivers for the library and tape drive. Before installing a driver, make sure it will not be in conflict with the software.

4.5 Troubleshooting

4.5.1 Fibre Channel Connection Problems

Navigate to **Status> Drive Status** to check the connection for your tape drive.

If the library reports that the drive is Logged Out:

- Check that the Fibre Channel speed is set to Automatic or that the correct Fibre speed is selected. If you are unsure of the speed of the HBA or switch that the drive is connected to, set to Automatic.
- Check that the correct port type, fabric or loop, is selected. Loop requires additional configuration. If you are unsure of the correct port type, set to Automatic.
- If Interface reports No Light Detected, ensure that the FC cable is connected properly to the drive as well as the switch/HBA.
- If the speed reports N/A, try setting the speed to Automatic.
- If there are still issues, change the port type to Auto Detect.
- If the screen shows ALPA Conflict:

There might be a conflict with the ALPA address on Loop ports. Select Soft for the Loop mode to allow the system to select an available address each time the tape drive connects to the FC fabric. If your server configuration does not support changing addresses, try using the Hard Auto-Select option for the Loop mode. This allows the system to select an available address when it first connects and then retain that address for future connections.

4.5.2 SAS Connection Problems

Navigate to **Status> Drive Status** to check the connection for your tape drive.

- If Interface reports Not Connected, ensure that the SAS cable is properly connected to the drive and to the HBA.
- Speed should be automatically set.
- If the operating system does not detect any devices on the HBA:
 - Verify that the SAS host adapter is installed correctly. Refer to the manual that came with your host adapter for installation and troubleshooting instructions. Pay particular attention to any steps describing configuration settings. Make sure that the host adapter is properly seated in

the motherboard slot and the operating system correctly detects the host adapter.

- If the operating system detects the tape drive, but not the library:
 - Verify that multiple LUN support is enabled on the HBA. The library uses two Logical Unit Numbers (LUNs) to control the tape drive (LUN 0) and robotic (LUN 1). Multiple LUN support must be enabled on the host computer. When multiple LUN support is not enabled, the host computer can see the tape drive, but not the library.



NOTE Many RAID or array controllers do not provide multiple LUN support.

- If the library is detected by the operating system, but not by the application software:
 - Refer to the documentation included with your backup application for instructions on how to verify proper installation. Some backup software packages require an additional module to communicate with the robotics.
- If the library is detected by the operating system, but is listed as an unknown or generic device:
 - Make sure that the proper device driver, if applicable, is installed for the device. Check your software provider's website for the latest drivers and patches.



NOTE Many backup applications use their own drivers. Before installing a driver, make sure it is not in conflict with the application software.

If you continue to have problems with a SAS library, check the following:

- Ensure that the library is compatible with the SAS host adapter and backup application you plan to use.
- Verify that your HBA is supported by the host computer and qualified with the library.
- Ensure you are using a compatible, high-quality cable.

4.5.3 Power Problems

Problem	Solution
Device does not power on.	<ol style="list-style-type: none"> 1. Check all power cord connections. 2. Check the LEDs on the power supplies. 3. Make sure the power button on the front panel has been pressed, and the green Ready LED is lit. 4. Make sure the outlet has power. Try another working outlet. 5. Replace the power cord.
No message appears on the OCP display.	<ol style="list-style-type: none"> 1. Check all power cord connections. 2. Check the LEDs on the power supplies. 3. Make sure the power button on the front panel has been pressed, and the green Ready LED is lit. 4. Make sure the outlet has power. Try another working outlet.

4.5.4 Move Problems

Problem	Solution
Tape stuck in drive.	<p>Try the following steps, in this order, to remove the stuck tape.</p> <p>NOTE: The tape drive must rewind the tape before ejecting it. This can take as long as five minutes, depending on how much tape must be rewound. Once the tape is rewound, the eject cycle will take fewer than 16 seconds.</p> <p>The Ready light flashes while the tape rewinds. Wait for the tape to finish rewinding before attempting another operation.</p> <ol style="list-style-type: none"> Attempt to unload the tape from your backup software. Shut down the backup software and stop the operating system's removable storage services. From the Operation > Move Media screen, attempt to unload or move the tape to a slot. Power down the library, disconnect the cable from the drive, power up the library, and wait until the tape drive is idle or ready. From the Operation > Move Media screen, attempt to unload or move the tape to a slot. From the Operation > Force Drive Media Eject screen, attempt a force eject or emergency unload operation. <p>IMPORTANT: Inspect the tape cartridge that was stuck. Damage or misplaced labels on the cartridge could have caused the load/unload failure. Discard any tape cartridge found to have issues.</p>
Tape cannot be removed from storage slot	<p>If the OCP or RMI is still operational:</p> <ol style="list-style-type: none"> Unlock the magazine from the Operation > Open Magazine screen and extend it to access the storage slot. Grasp the cartridge and remove it from the storage slot. Some tapes need to be inserted and removed several times to condition them for free movement in and out of the magazine. Check the barcode label and verify that it is secure to the cartridge. Check the cartridge for damage. Check the storage slot for damage.

4.5.5 Media Problems

Problem	Solution
Cleaning or data cartridge incompatible with drive.	<ol style="list-style-type: none"> Check the event log to see which cartridge is incompatible. Make sure you are using data and cleaning cartridges that are compatible with the drive and model of your device and that you are using the correct cartridge type for the operation. The device automatically unloads incompatible cartridges, the Attention LED flashes. Export the media.
Cannot write to or read from	<ol style="list-style-type: none"> Make sure that the cartridge is not a WORM cartridge that

Problem	Solution
tape.	<p>has already been used.</p> <ol style="list-style-type: none"> 2. Make sure that the cartridge is write enabled (move the write-protect switch to the enabled position). 3. Make sure the data cartridge is compatible with the drive model. LTO tape drives can read data cartridges from two generations back and write to data cartridges one generation back. 4. Make sure you are using an Ultrium cartridge that has not been degaussed. Do not degauss Ultrium cartridges! 5. Make sure that the cartridge has not been exposed to harsh environmental or electrical conditions and is not physically damaged in any way. 6. Many backup applications do not read or write to cartridges that were created using a different backup application. In this case, you may have to perform an erase, format, or label operation on the cartridge. 7. Make sure you understand any data protection or overwrite protection schemes that your backup application may be using, which could prevent you from writing to a given cartridge. 8. Retry the operation with a different, known good tape. 9. Clean the tape drive from the Operation > Clean Drive screen.

4.5.6 LED is Lit

Problem	Solution
Both the Attention and Cleaning LEDs are lit.	<p>This is most likely caused by a dirty drive that cannot read a tape and marks the tape invalid.</p> <p>Log into the OCP or RMI and check the event log to see which drive has reported that it needs cleaning. Clean the drive with an approved Ultrium cleaning cartridge.</p>
A particular cartridge sets off the cleaning light.	Remove the cartridge from the library.
A cartridge recently imported from a different environment is causing issues.	Media that is moved from one environment to another can cause issues until it has acclimated to the new conditions. A cartridge should be acclimated for at least 24 hours before being used, particularly if it has been stored at a substantially different temperature or level of humidity than the device.
The Attention LED is lit but the Cleaning LED is not lit after a cartridge load.	<ol style="list-style-type: none"> 1. The library was unable to complete the requested operation with the selected tape cartridge. 2. Use only cartridges that are compatible with the drive type

Problem	Solution
	<ol style="list-style-type: none"> Use the correct type of cartridges for the operation. For example, use a cleaning cartridge for cleaning. Make sure you are using an Universal cleaning cartridge
The Cleaning LED is lit after using a cleaning cartridge.	The cleaning cartridge has expired. A cleaning cartridge will expire after 50 cleaning cycles.
A particular cartridge sets off the Attention LED and possibly the Cleaning LED.	<ol style="list-style-type: none"> Retry the operation with a different cleaning cartridge. If the Attention LED is cleared and the drive has been cleaned, and then immediately re-displays each time a particular cartridge is reloaded, that cartridge should be suspected as being defective. If this occurs, export the cartridge and load a known good cartridge. In some cases, a cartridge can be worn out, have a defective Cartridge Memory, or have been formatted as a Firmware Upgrade Cartridge. Any cartridge that is suspected of being defective or contaminated should NOT be reused in any drive. If the bad cartridge is a cleaning cartridge, it might be expired.

4.5.7 Inventory Problems

Problem	Solution
The library displays incorrect bar codes.	<ol style="list-style-type: none"> Verify that the label is properly applied. Verify that the label is not soiled.

4.5.8 RMI Issues

Problem	Solution
Cannot connect to the RMI.	<ol style="list-style-type: none"> Verify that the Ethernet cable is connected to the library's controller board and to the LAN. Verify that the link LED on the RJ45 (LAN) connector is lit when the device is powered up. If the LED is not lit, the device is not communicating with the LAN. See your network administrator for help. Verify that the device has been configured with a valid static network address or DHCP has been enabled so the device can obtain a network address. If using DHCP, write down the device's network address from the OCP login screen. If the device did not obtain a valid address via DHCP, verify that the DHCP server is up and the library has network access to it. If necessary, set a static network address instead. Enter the library's IP address into the address bar of a

Problem	Solution
	web browser connected to the same LAN as the device. If the RMI web page does not display, ping the device's IP address. If the ping fails, verify that the device has a valid network address and that there are no firewalls or other obstructions to network traffic between the computer with the web browser and the device. See your network administrator for help.

4.5.9 Performance Issues

The process of backing up data to tape drives involves many system components. The backup process can only run as fast as the slowest component in the system.

Performance issues are solved by identifying and addressing performance limitations in your system. The items that need to be considered are:

- Average File Size
- File System Type
- Connection from the Backup/Archive Host Server to the Disks
- Backup/Archive Server
- Backup/Archive Software and Method
- Connection from the Backup/Archive Host Server to the Device
- Media

Average File Size

If the average file size of the data being backed up is small, the read performance will be lower because more time is needed to seek the start of each new file.

To determine the average file size, divide the size of the backup by the number of files.

If the average file size is small (64 KB or less), consider using a sequential, image, or block backup method that backs up the whole hard drive or LUN image instead of individual files. The trade off for using one of these methods is that you might only be able to restore the entire image instead of individual files.



NOTE

File fragmentation will also cause excessive drive seeking, which lowers performance, so ensure that files are regularly defragmented.

File Storage System

The file storage system determines the organization of the files on the disks. Using RAID controllers to spread files over multiple disks can improve performance because some disks can be seeking while others are reading. Storing files on a single non-RAID disk results in the slowest performance while storing files on a high-end disk array results in the fastest performance.

Connection from the Backup Host Server to the Disk Array

The connection between the host server and the disks determines how much data can be transferred from the disks to the host computer. A connection with insufficient bandwidth cannot provide enough data for the tape drives to write at full speed. For optimum performance, the storage subsystem must be able to provide data at the tape drive's maximum transfer rate.

Backup systems using a lower speed Ethernet network should use multiple network connections.

Backup/Archive Server

The backup server must have enough RAM and processor power to transfer the files from the disk to the tape drive, in addition to running the backup or archive software and any other processes. Check the RAM and processor usage during a backup operation. If they are operating at capacity, adding RAM or processor capability can improve performance.

Media

The type and condition of the media also affect backup performance. For best performance, use media that is the same LTO generation as the tape drives.

4.6 Removing the Magazines

It is recommended that you open the magazine using the OCP or RMI. If these methods fail, or if a magazine needs to be removed when the power to the device is off, you can release the magazine manually.

To manually release the magazine, insert a small flat head screwdriver or other small pin into the appropriate magazine release hole and gently push the tab in.



IMPORTANT

Do not exert force once you encounter resistance. Doing so can damage the device.

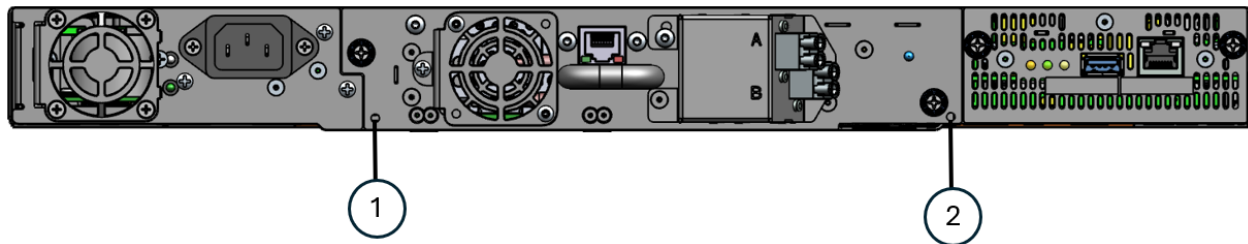

4.7 Ejecting a Stuck Tape

If the tape is stuck in a tape drive, eject the tape from the drive from the **Operation > Force Drive Media Eject** screen.

If a tape is stuck in a magazine, open the magazine, grasp the cartridge, and pull it out of the storage slot.

5 Packaging the unit for transportation



WARNING

Weight of Q8 Tape Library - Risk of personal injury

Before lifting a library:

- Observe local health and safety requirements and guidelines for manual material handling.
- Obtain adequate assistance to lift and stabilize the library during packaging.



NOTE

- Before transporting the library, the shipping lock and the yellow label must be replaced into the slot on the top cover of the library from its storage slot on the rear panel.

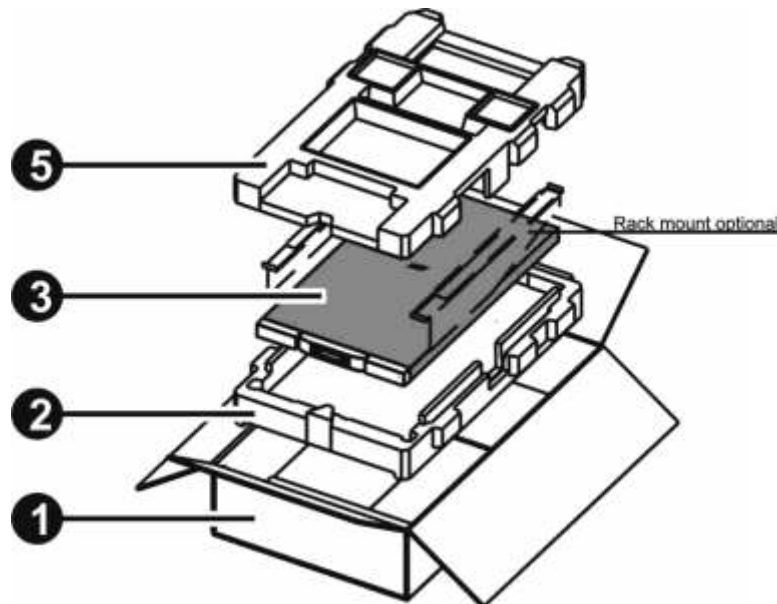

Figure 22 Packaging the Q8

Step	Description
1	Packaging box
2	Bottom shell
3	Library
5	Top shell

6 Technical specifications

6.1 Hardware specifications

Library Model	Q8
Height	Product alone: 1.8" / 4.56 cm Packaged: 9.3" / 23.5 cm
Width	Product alone: 17.5" / 44.45 cm Packaged: 23.2" / 58.9 cm
Depth	Product alone: 31.1" / 78.95 cm Packaged: 39.1" / 99.3 cm
Weight without media	25 lb / 11.4 kg
Weight with media	29 lb / 13.1 kg

6.2 Operating environment

Operating	Temperature	10°C to 35°C
	Max. temperature rise	10 °C / hour
	Humidity	15 % RH to 85 % R.H. (non-condensing)
	Maximum wet bulb	26 °C
	Max. humidity rise	10% / hour
	Altitude operating	0 to 13,000 ft. (4200 m) at 25 °C ambient
Non-operating Storage and Shipping	Temperature	-40 °C to +60 °C
	Max. temperature rise	20°C / hour
	Humidity	5 % RH to 90% RH (non-condensing)
	Altitude	-7 m to 10,668 m (-22 to 35,000 feet)

7 Regulatory Information



NOTE

- To comply with the following regulations and standards, the library must be properly installed in an office or industrial environment with shielded cables and adequate grounding of the input power source.

7.1 Recycling and disposal



NOTE

- Disposal of waste equipment by users in private household in the European Union and Norway.

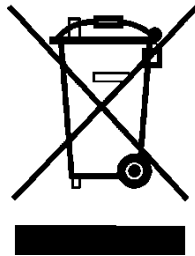

Figure 70 WEEE symbol

This symbol on the product or on its packaging indicates that this product must not be disposed of with your other household waste. Instead, it is your responsibility to dispose of your equipment by handing it over to a designated collection point for the recycling of waste electrical and electronic equipment. The separate collection and recycling of your waste equipment at this time of disposal will help to conserve natural resources and ensure that it is recycled in a manner that protects human health and the environment. For more information about where you can drop off your waste equipment for recycling, please contact your local city office, your household waste disposal service or the shop where you purchased the product.

CE Mark



The CE mark is a mandatory conformity mark on many products placed on the single market in the European Economic Area (EEA). The CE marking certifies that a product has met EU consumer safety, health or environmental requirements.

CCL Mark

FCC (United States)

The computer equipment described in this manual generates and uses radio frequency (RF) energy. If the equipment is not installed and operated in strict accordance with the manufacturer's instructions, interference to radio and television reception might result.



This equipment complies with Part 15 of the FCC Rules. Operation is subject to the following conditions: (1) This device may not cause harmful interference, and (2) this device must accept any interference received, including interference that may cause undesired operation.

Part 15, Class A, of the FCC Rules, is designed to provide reasonable protection against radio and television interference in a residential installation. Although the equipment has been tested and found to comply with the allowed RF emission limits, as specified in the above-cited Rules, there is no guarantee that interference will not occur in a particular installation. Interference can be determined by turning the equipment off and on while monitoring radio or television reception. The user may be able to eliminate any interference by implementing one or more of the following measures:

- Reorient the affected device and/or its receiving antenna.
- Increase the distance between the affected device and the computer equipment.
- Plug the computer and its peripherals into a different branch circuit from that used by the affected device.
- If necessary, consult an experienced radio/television technician for additional suggestions.

Canadian Verification

This Class A digital apparatus meets all requirements of the Canadian Interference-Causing Equipment Regulations (ICES-003, Class A).

8 Default Settings

Setting	Default for the library
Initial admin password	adm001
Host name	FLX + last 6 characters of MAC address e.g. MAC = 000E11801907, host name = FLX801907
Domain name	<i>localdomain.com</i>
IPv4	Enabled
IPv6	Disabled
DHCP	Enabled
Mail slot configuration	Disabled
Configure reserved slots	Reserved slots = 0
SCSI master drive	The lowest physical drive is initially the LUN master drive
OCP contrast setting	10
Library Mode	Automatic
Auto load	Disabled
Loop	Disabled
Drive power <ON/OFF>	All drives are powered <ON>
Auto clean	Disabled
SNMP	Disabled
FC tape drives	Automatic speed, auto topology
Log Tracing Configuration	All selected
Email notification	No events
Partitioning	Partitioning is turned <OFF>

9 Glossary

FC	Fibre channel
FH	Full-height
HBA	Host bus adapter Connects a host system to other network and storage devices
HH	Half-height
LED	Light Emitting Diode
LTO	Linear Tape-Open Magnetic tape data storage technology
LUN	Logical Unit Number Unique number assigned to each device attached on a SCSI bus. For example, disk and tape drives, media changer, etc.
OCP	Operator Control Panel Includes display, buttons and LED's and enables the user to operate
PCB	Printed Circuit Board Example: Library controller
RMI	Remote Management Unit Provides the capability to operate the unit through a web based remote management interface
SAN	Storage area network Architecture to attach remote computer storage devices
SAS	Serial Attached SCSI Computer bus, which moves data to and from computer storage devices such as hard drives and tape drives
SCSI	Small Computer System Interface Communication interface to the host system
USB	Universal Serial Bus

10 Index

Agency certifications	92	Factory defaults	52
Canadian verification	94	Library identity, dynamic	36
CE mark	93	Login	34
Device standards	93	Operations	53
ETL mark	93	Reboot library	56
FCC mark	94	Status	40
Recycling and disposal	92	Packaging	88
Default settings	59	Product overview and features	1
Electrostatic discharge	82	Front panel	2
Error codes	67	Rear panel	4
General warnings	iv	Q8 Power supply	4
Installing	6	Tape drive	5
Cabling	16	Servicing	82
Ethernet cable	18	Base chassis	86
FC cable	17	Library controller	84
Power cord	16	Magazine	85
SAS cable	17	Power supply	85
FC requirements	7	Tape drive	83
FC topology (Fabric)	8	Sub error codes	79, 81
Host verifying	18	Technical specifications	
Library controller	15	Hardware specifications	90
Location requirements	6	Troubleshooting	60
Magazines	22	Backup	60
Powering up/down	18	Bad performance	61
Precautions	9	Cleaning cartridge	61
Product components	10	Compatibility	62
Rack mounting	12	Device driver	60
Removing the shipping lock	11	Diagnostic	66
Serial attached SCSI (SAS)	6	Library verify test	66
Tape cartridges	18	Slot-to-Slot test	66
Labeling	20	System test	66
Type	18	Emergency release	65
Using	19	Error codes	67, 69
Write-protecting	21	Error on OCP	61
Tape drive	14	Firmware	66
Unpacking the library	10	Installation problems	60
USB device	18	Media	62
Operating	23	Media Attention LED	63
OCP	23	Power	62
Operating modes	23	Stuck tape cartridges	64
Philosophy	23	Sub error codes	79, 81
RMI	33	Tape cartridge movement	63
Date/time	49		