



TLS-412xxx

Product Specification

500119 Rev. D

Copyright Notice

Copyright® 2004 by Qualstar Corporation — All Rights Reserved

Information contained in this document is copyrighted by Qualstar Corporation. It is intended for use by Qualstar's customers and prospective customers to evaluate, integrate, operate and maintain Qualstar products. Customers and prospective customers may reproduce this document as needed for these uses. Reproduction in whole or in part for any other use or by any other party is prohibited without prior written permission from Qualstar Corporation.

Every effort has been made to keep the information contained in this document current and accurate as of the date of publication or revision. However, no guarantee is given or implied that the document is error-free or that it is accurate with regard to any specification.

Qualstar reserves the right to modify the design or specification without notice. This specification may not be construed as a contractual obligation except as specifically agreed to by Qualstar in writing at the time of order.

Qualstar and the Qualstar logo are registered trademarks of Qualstar Corporation. Other trademarks are the property of their respective owners.

Notices

Qualstar products are covered by one or more of the following patents: 6,163,139 and 6,560,061. Other patents pending.

Qualstar equipment is manufactured from new parts, or new and used parts. In some cases, Qualstar equipment may not be new and may have been previously installed. Regardless, Qualstar's warranty terms apply unless the equipment is specifically identified by Qualstar as "used" or "refurbished".

This equipment has been tested and found to comply with the limits for a Class A digital device, pursuant to Part 15 of the FCC Rules. These limits are designed to provide reasonable protection against harmful interference when the equipment is operated in a commercial environment. This equipment generates, uses, and can radiate radio frequency energy and, if not installed and used in accordance with the instruction manual, may cause harmful interference to radio communications. Operation of this equipment in a residential area is likely to cause harmful interference in which case the user will be required to correct the interference at his own expense. Shielded cables are required for this device to comply with FCC Rules. Use shielded cables when connecting this device to others.

For information about this product specification, please write or call Qualstar at:

QUALSTAR CORPORATION

3990-B Heritage Oak Court
Simi Valley CA 93063

FAX: (805) 583-7749
Phone: (805) 583-7744

E-Mail: sales@qualstar.com
www.qualstar.com

Table of Contents

1.	Introduction.....	1-1
1.1	Scope.....	1-1
1.2	Supplemental Documentation	1-1
2.	Product Description	2-1
2.1	General Description.....	2-1
2.2	Features Common to All Models.....	2-2
2.3	Available Models.....	2-3
2.4	Q-Link.....	2-4
2.5	Field Expansion Kits	2-4
2.6	Controls and Indicators.....	2-4
2.7	Cartridge Handling System	2-5
2.8	Cartridge Inventory Security.....	2-6
2.9	Cartridge Access	2-7
2.9.1	Data Cartridge Magazines.....	2-7
2.9.2	I/O Port.....	2-7
2.10	Barcode Readers	2-7
2.11	Barcode Labels.....	2-8
2.12	Cooling System	2-8
2.13	SCSI Interface.....	2-8
2.13.1	Standard SCSI LVD/SE Cabling for TLS-412xxx Libraries.....	2-9
2.13.2	External Cable Requirements	2-9
2.13.3	SCSI Connectors.....	2-9
2.13.4	SCSI Terminators.....	2-9
2.13.5	SCSI Termination Power	2-10
2.14	Operating Firmware.....	2-10
2.15	Random and Multi-Sequential (Multiple Stacker) Operation	2-10
2.16	Manual Operation.....	2-11
2.17	Logical Libraries	2-12
3.	Physical Specifications	3-1
3.1	Dimensions and Weights.....	3-1
3.2	Standard Colors	3-3
3.3	Custom Logo Provision.....	3-3
3.4	Tape Drive and Data Cartridge Compatibility.....	3-3
4.	Electrical Specifications.....	4-1
4.1	Power Requirements and Consumption.....	4-1
4.2	Power Source Disturbances	4-1
4.3	Power Entry	4-2

4.4	Power Supplies.....	4-2
5.	Agency Compliance.....	5-1
5.1	EEC Directive Compliance (European Economic Community).....	5-1
5.2	Emissions/Immunity Standards Compliance	5-1
5.3	Safety Standards Compliance.....	5-1
6.	Performance Specifications.....	6-1
6.1	Data Cartridge Handling Times	6-1
6.2	Scan All Barcodes	6-1
7.	Environmental Specifications.....	7-1
7.1	Temperature, Humidity and Altitude	7-1
7.2	Acoustical Noise	7-1
8.	Reliability Specifications	8-1
8.1	Mean Exchanges Between Failures	8-1
9.	Maintainability	9-1
9.1	Mean Time To Repair.....	9-1
9.2	Preventive Maintenance.....	9-1
9.3	Automated Tape Drive Cleaning	9-1
9.4	Adjustments	9-1

1.

Introduction

1.1 Scope

This product specification describes the Qualstar TLS-412xxx Tape Library Systems, subsequently referred to in this specification as the TLS-412xxx, or simply as the TLS. It also provides detailed specifications of the product. It is intended for use in evaluating, purchasing and integrating the TLS-412xxx library products.

1.2 Supplemental Documentation

For information about the SCSI interface, or other information outside the scope of this manual, please refer to the appropriate documents listed below. The following Qualstar and ANSI documents supplement this specification:

SUBJECT	DOCUMENT	QUALSTAR DOCUMENT
Installation & Operation	TLS 412xxx Installation and Operation Manual	501300
Service	TLS 412xxx Technical Service Manual	501290
Remote Operation	Q-Link Remote Library Manager Installation Guide	501520
Supported Tape Drives	Product Information Note	PIN-014
Approved Data Cartridges	Product Information Note	PIN-038
Barcode Label Specifications	Product Information Note	PIN-040
SCSI Command Information	TLS 4000 SCSI-2 Interface Manual	500523
SCSI-2	ANSI X3.131-1994	N/A
SCSI SPI-2 Specification	ANSI X3.302-1998 SCSI Parallel Interface-2 (SPI-2)	N/A
SCSI SPI-3 Specification	T10 Project 1302D SCSI Parallel Interface- (SPI-3)	N/A

Table 1-1 Applicable Documents

2.

Product Description

2.1 General Description

The TLS-412xxx models are an extension of the TLS-4000 family of reliable, automated tape library systems that use eight millimeter (8mm) tape drives and data cartridges. Data capacities for the four available models range from 9 to over 312 terabytes. One to twelve tape drives can be installed. The entire system (drives and library) is under host control via an ultra SCSI interface. A Fibre Channel interface option is available. Q-Link, a web based remote library manager is also available. Please see the TLS-4000 Product Specification (Qualstar document number [500563](#)) for a description of the TLS-4000 family.

Each library contains a high performance robotics system for handling data cartridges, a drive bay to accommodate the tape drives, and removable magazines for data cartridges. All units operate on any internationally available AC power source. The entire cabinet is pressurized and cooled by filtered air to ensure an optimum environment.

The TLS-412xxx models are designed for maximum reliability. Only the highest quality components are used in a design that is inherently robust and simple. There are no belts or pulleys to stretch or wear out in any of the motion axis'. Instead, brushless motors operate precision lead screws. Digital closed-loop servo systems and Hall-Effect position sensors assure fast, smooth, trouble-free cartridge handling. The servos automatically calibrate themselves, thus eliminating all electrical adjustments. Preventive maintenance is reduced to cleaning and replacing the air filter, when so prompted by the control panel display.

2.2 Features Common to All Models

- Key-locked access door with a large window
- No mechanical or electrical adjustments required
- Barcode scanning of data cartridges supported in all models
- Automated I/O Port for inserting and removing cartridges
- 1,000,000 Mean-Exchanges-Between-Failures rating
- All brushless DC motors
- Precision leadscrew driven mechanisms (no belts or pulleys)
- Q-Link Remote Library Manager
- Back-lighted 80-character display
- Menu driven control system for use in system configuration, operation and maintenance
- Pressurized, filtered, forced air cooling of library and tape drives
- Simple system integration to any host computer through a SCSI interface
- Twelve pre-wired tape drive mounting bays
- Fibre Channel Interface option
- Inventory Sentry feature minimizes off-line time
- Maintenance-friendly by design, self-calibrating, all-digital servo control system
- Operating firmware updateable via the SCSI interface or Q-Link
- Wide input voltage range (100 VAC to 240 VAC)
- High degree of common parts with other models in the TLS-4000 family
- Simultaneous Random and Multi-Sequential (Multiple Stacker) operating modes in multi-drive models
- Logical Libraries feature supports simultaneous connections to as many as four hosts
- Automated tape drive cleaning
- Non-volatile RAM stores configuration data when power is removed

2.3 Available Models

Available models and a list of their features are shown below.

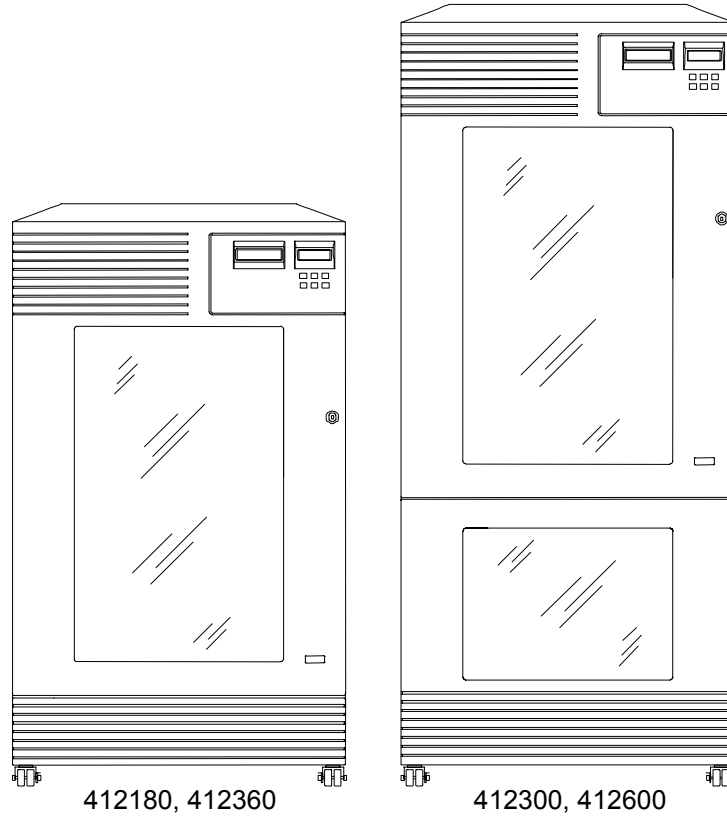

FEATURE/MODEL	412180	412360	412300	412600
Maximum number of tape drives	12	12	12	12
Media capacity in cartridges (10 cartridges per magazine)	180	360	300	600
Barcode Readers	Std.	Std.	Std.	Std.
I/O Port for automated cartridge insertion/removal	Std.	Std.	Std.	Std.
Carousels (rotary positioning of magazines)	2	2	2	2
Magazine configuration (# high x # side)	3x3	3x6	5x3	5x6
Fibre Channel Option	Opt.	Opt.	Opt.	Opt.
Q-Link Remote Library Manager	Opt.	Opt.	Opt.	Opt.

Table 2-1 Available Models

2.4 Q-Link

Q-Link is Qualstar's remote tape library monitoring and management system. Q-Link provides the key information needed to monitor and manage the TLS from anywhere in the world. Q-Link supports total remote operation of the library. Any function that can be executed locally from the operator control panel can be performed over the worldwide web via Q-Link. Q-Link utilizes an easy-to-use graphical interface accessed over a web browser, and supports up to ten individual user accounts.

The TLS Executive firmware and the Q-Link firmware can both be uploaded remotely via Q-Link. Q-Link can also automatically send e-mail messages to a predefined list of recipients whenever selected faults, alarms or alerts occur or the TLS requires maintenance.

2.5 Field Expansion Kits

Expansion kits are available to increase the library capacity to meet increased storage requirements after a unit has been installed. The kits consist of the appropriate hardware to allow a field engineer to upgrade a unit in less than 60 minutes. The following models may be converted by installing field expansion kits:

FROM MODEL	TO MODEL
412180	412360
412300	412600

Table 2-2 Field Expansion Kits

2.6 Controls and Indicators

The control panel is located at the top of the TLS and contains a four-line, 80-character display and six momentary push-button switches. An audible alarm alerts the operator to error conditions.

The multi-purpose display shows the following information, depending upon the selected mode of operation:

- Model number, identification number and firmware revision
- Operational status
- SCSI command display
- SCSI command history log which stores the most recent commands and status
- Error conditions
- Extensive menu system for configuration, maintenance, operation functions
- Configuration and Control of Fibre Channel Interface

The six push-button switches are used to manually control the TLS by means of the menu system and are identified in Table 2-3.

NAME	FUNCTION
▲	Scrolls up through menu items.
▼	Scrolls down through menu items.
ENTER	Accepts the currently displayed menu choice.
EXIT	Exits the present menu and returns to the previous menu level.
✱	Programmable response.
MENU	Always takes you to the Top Menu.

Table 2-3 Control Panel Switches

2.7 Cartridge Handling System

Figure 2-1 shows some of the major internal components of the TLS.

The front door provides easy access to the cartridge bay and robotic handlers and can be locked with a key to prevent unauthorized access. Opening the door disables the robotic handlers but not the tape drives.

Cartridges are stored in ten-cartridge magazines, which are easily removed and replaced. A positive locking system assures the magazines are securely fastened.

All models utilize two rotating carousels to present the desired magazine to the robotic handlers. Optical sensors assure accurate carousel positioning.

The robotic handlers consist of two independent carriages, which move data cartridges up and down between the tape drives and the magazines, and carriage-mounted loaders which move the cartridges in and out of the drives and magazines. The robotic handlers are self-aligning and do not require electrical or mechanical adjustment after tape drives are added or exchanged.

A leadscrew driver shuttle mechanism is found on all models for moving cartridges laterally between the two handlers so that any tape cartridge may be placed in any tape drive or storage location.

Brushless DC motors turn precision nuts around stationary lead screws to drive the carriages in the vertical axis. As the nuts turn, the carriages move up or down the lead screws. Linear ball bearings on two hardened shafts provide lateral and torsional support. Hall-effect sensors are utilized to provide commutation, position and velocity feedback for the control system. This unique design produces optimum positioning accuracy, reliability and long life.

Brushless DC motors turning precision lead screws drive the carriage-mounted loaders. Again, magnetic sensors provide position and velocity feedback, while optical sensors provide absolute position information. Solenoids release the spring-loaded cartridge gripping mechanisms.

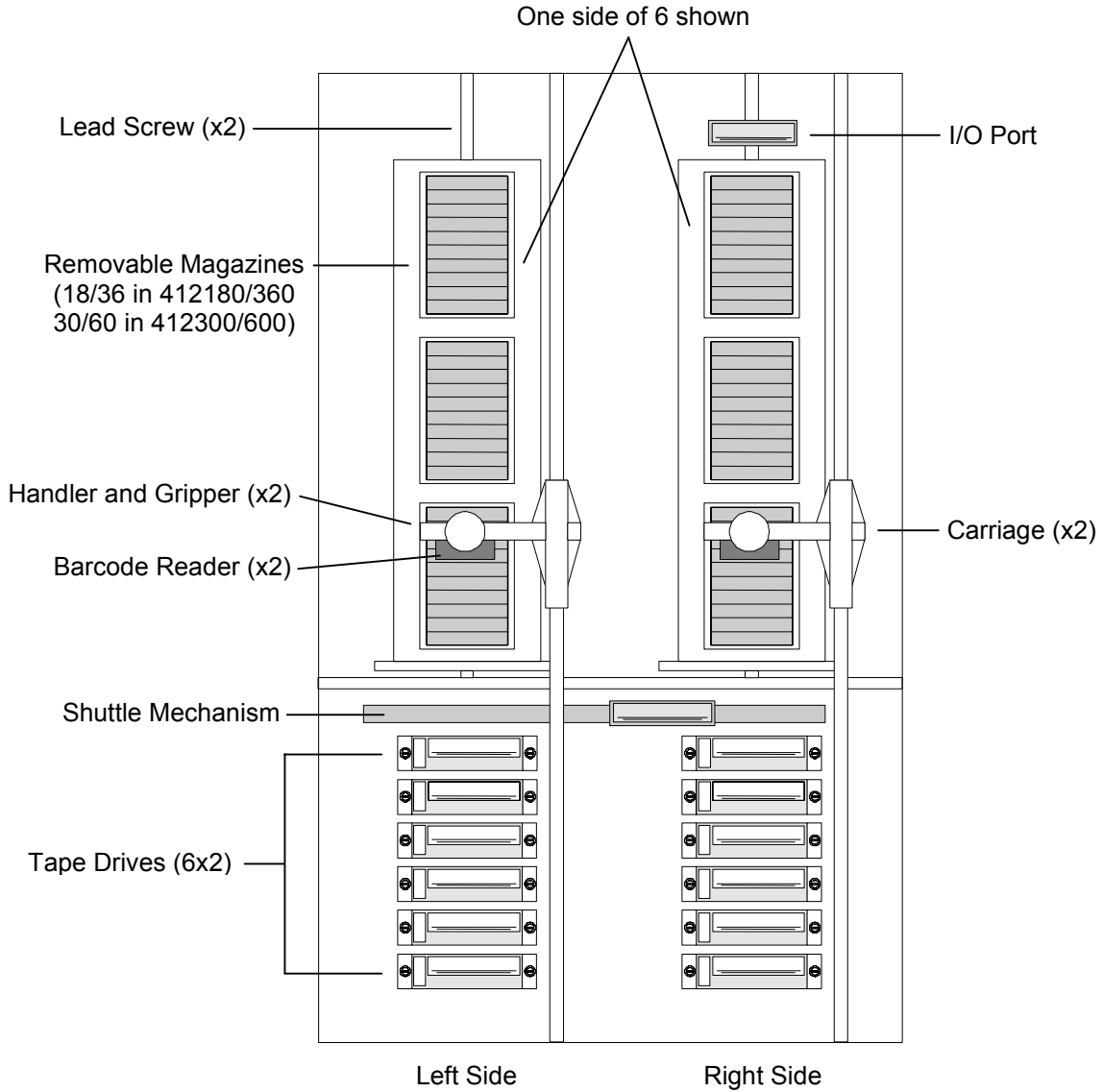

Figure 2-1 TLS Major Internal Assemblies – 412180/360 Model Shown

2.8 Cartridge Inventory Security

The Inventory Sentry utilizes infrared beams that pass (vertically) in front of all cartridge storage locations and tape drives. If the door is opened to inspect the inventory and if the inventory is not disturbed, closing the door immediately returns the TLS to operational status.

If either beam is broken while the cabinet door is open, by someone moving a cartridge for example, the TLS inventory status is invalidated. When the door is closed, the TLS will automatically rescan the cartridge inventory (and barcode labels if present) and update its internal inventory database before becoming operational.

2.9 Cartridge Access

2.9.1 Data Cartridge Magazines

Bulk exchange is performed by removing an entire cartridge magazine. Magazines snap easily into and out of the library system without tools. The robotic handlers are disabled when the door is opened for magazine removal or installation. A dust cover is included with each magazine for storage outside the TLS.

2.9.2 I/O Port

All models have an I/O Port that provides an automated means of inserting or removing cartridges, one at a time, from the library. A control panel request allows the user to access to the I/O Port. The I/O Port automatically retracts when a data cartridge is fully inserted.

The disposition of cartridges into or out of the I/O Port is handled either automatically by the host computer or manually by using the menu system. The host system software can assume complete control of the I/O Port for enhanced data security and can prevent access to the media via the control panel.

The I/O Port is operated by a lead screw and is monitored by optical sensors to ensure proper data cartridge insertion by the user.

2.10 Barcode Readers

Two barcode readers are standard on all models. Barcode readers are able to uniquely identify each cartridge without having to read the tape within. The use of barcode readers requires that each cartridge is identified by a barcode label. Preprinted barcode labels, which are both human- and machine-readable, are available from a number of sources. Including Qualstar.

The barcode readers consist of a charge-coupled sensor (similar to that used in a video camera) and associated electronics. A barcode reader is mounted under each carriage. The barcode reader can scan all cartridges in the TLS (except those loaded inside tape drives), as well as cartridges introduced into the I/O port. The changers must move cartridges in some upper slots, including the I/O port, to a temporary location before their barcode labels can be read. Barcode data is stored internally in the changer's non-volatile RAM (the internal inventory database) and is available to the host computer upon request.

2.11 Barcode Labels

Pre-printed barcode labels, which are both human- and machine-readable, are available from a number of sources including Qualstar.

Barcode labels must conform to ANSI/AIM BCI-1995, Uniform Symbology Specification Code 39. Please refer to [PIN-040](#) at www.qualstar.com (click on Support tab) for more information.

By default, the TLS expects a modulus 43 check character at the end of each label. The use of a check character helps assure that labels are read error-free. The TLS configuration must be changed before using barcode labels without a check character. All of the labels within the TLS must match the check character configuration: either all with or all without a check character.

2.12 Cooling System

Axial-flow fans draw outside air into the cabinet through replaceable air filters. The resulting inside positive pressure prevents dust and debris from entering the TLS. Air is exhausted through vents at the top and rear of the enclosure.

2.13 SCSI Interface

For the sake of clarity and compliance with the SCSI specifications, the controller portion of the TLS is defined as a “Medium-changer” abbreviated as “MC”. The standard SCSI control-interface to the Medium-changer is both Low-Voltage Differential (LVD) and Single-Ended (SE) capable. This is defined by ANSI as Multi-Mode Low Voltage Differential or MLVD and is called LVD/SE in the vernacular. A High Voltage Differential (HVD) SCSI interface is optional.

Tape drives are available in all of these interface types. All devices on a single SCSI bus must be compatible with each other as indicated in Table 2-4 below. Wide (16-bit) and narrow (8-bit) devices may always be mixed together on the same bus.

Interface Type	Bus Compatibility
HVD	May not be mixed with any other type.
LVD	May not be mixed with HVD or SE.
MLVD (LVD/SE) (Multimode)	May be mixed with single-ended (SE). The bus operates in the SE mode when SE device is present.
Single-ended (SE)	May be mixed with MLVD (LVD/SE). The bus will always operate only in the single-ended mode.

Table 2-4 SCSI Interface Compatibility

2.13.1 Standard SCSI LVD/SE Cabling for TLS-412xxx Libraries

All TLS-412xxx SCSI cabling consists of high-performance, 68 conductor Ultra SCSI cable to provide for the highest possible data transfer rates.

Due to the size of the library and the high number of SCSI devices possible within it, the SCSI cabling has been partitioned into two independent sides – the left and the right sides (as viewed from the cabinet front). Each side has its own distinct SCSI interface to the Medium-changer. These two Medium-changer should never be connected together on the same SCSI bus. The ports to the Medium-changer are physically identical and logically equal to each other.

Please refer to the SCSI Hatch Reference Document (Qualstar document number [400095](#)) for additional information.

2.13.2 External Cable Requirements

The SCSI specifications require higher performance external cables to facilitate the faster data transfer rates. The following is a brief cable specification for purchasing purposes:

1. The cable is to meet the requirements of American National Standard for SCSI Parallel Interface-2, Document No. X3.302:1998 for transfer rates up to Fast-20 or the Working Draft American National Standard T10 Project 1320D for transfer rates up to Fast-80.

2.13.3 SCSI Connectors

The standard connector on the TLS rear panel is an HD68 (68-pin female, wide, high-density, SPI-2) connector (AMP P/N 786096-7 or equivalent). The mating connector should be an AMP 750752-1 or equivalent. The standard jackscrew locking hardware is utilized.

2.13.4 SCSI Terminators

The SCSI bus must be properly terminated at each of its ends. The host adapter board is usually terminated. The other end usually appears at the library and requires the installation of a SCSI terminator. The recommended terminators are listed in Table 2-5.

SCSI Bus Type	QUALSTAR P/N
Low Voltage Differential or Single-Ended – LVD/SE	117-0011-9
High-Voltage Differential – HVD	117-0006-9

Table 2-5 68 Pin SPI-2 Terminators

2.13.5 SCSI Termination Power

Each TLS SCSI control port can supply up to 2 amps of termination power to the SCSI bus. This termination power is fed to the SCSI bus TERMPWR line through a circuit protector, a blocking diode and a jumper (TPWR), as shown in Figure 2-2. The termination power is periodically monitored and, if it is missing, the front panel will display an appropriate error message. For tape drives isolated from the termination on the TLS' control port, termination power can be provided by the tape drive itself.

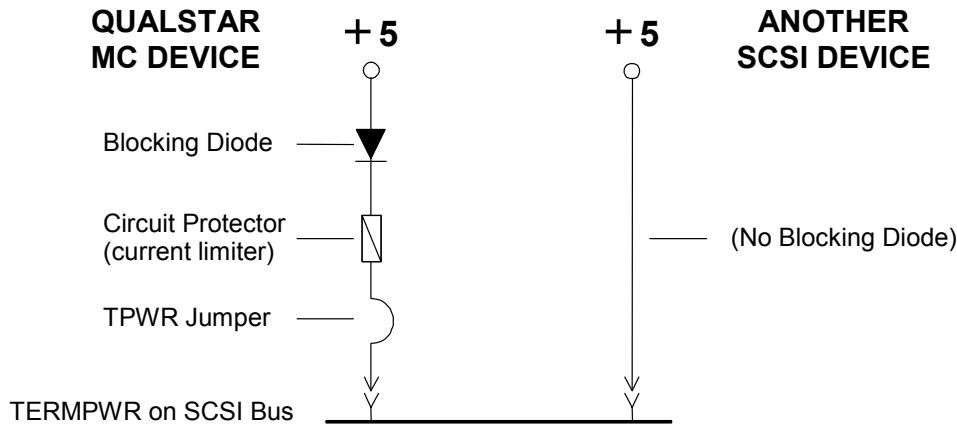

Figure 2-2 SCSI Termination Power Diagram

2.14 Operating Firmware

The operating firmware for the TLS-412xxx is contained in flash memory. It can be updated in the field through the SCSI interface, or via the Q-Link remote manager. The TLS-412xxx models can emulate the SCSI-2 interface protocol of competitive products, including the following Exabyte models: EXB 10e, EXB 10i, EXB 120, EXB 210, EXB 218, EXB 440, and EXB 480.

2.15 Random and Multi-Sequential (Multiple Stacker) Operation

Each tape drive and cartridge storage location in the TLS may be configured through the menu system for Random or Sequential operation. If a tape drive is configured for the Random mode, it becomes a resource to be controlled by an application that will operate the library. If a drive is configured for the Sequential modes, it is referred to as a sequential drive and is marked unavailable in the list of resources reported. Sequential drives are instead manually controlled via the library control panel.

For Sequential or Recycle operation, a single contiguous range of cartridge locations is assigned to each sequential drive for its exclusive use. In these modes, each tape cartridge is returned to its original storage location after it is ejected from the tape drive.

For Dual-Bin operation, two separate ranges of magazine locations are assigned to each sequential drive for its exclusive use. The Input range of locations is where the

changer removes cartridges to be placed in the sequential drive. The Output range is where those cartridges are returned after the drive has ejected them.

Cartridge storage locations assigned to sequential operations are marked as being unavailable in the list of resources reported to host computers. Empty slots in a Sequential, Recycle or Dual-Bin drive's storage location range will not adversely affect operation.

When a Sequential or Recycle operation is started (via the menu system), the changer moves the first cartridge, found at (or after) the initial specified storage location into the drive. When the drive ejects the cartridge, the changer automatically returns the cartridge to its original location. The changer then places the next cartridge, found within the drive's storage range into the drive. This process is repeated, until the last specified cartridge is ejected and returned to storage. This sequence may be started at any location within a Sequential drive's storage range but will always end at the last storage location. In Recycle operations, the handler will return to the starting position and repeat the cartridge movement cycle indefinitely.

When a Dual-Bin operation is interactively started (via the menu system), the changer moves the cartridge found at (or after) its Input First location into the drive. When the drive ejects the cartridge, the changer automatically places it in the first empty cartridge location in the drive's Output range. This process is repeated, until the last specified cartridge in the Input range has been ejected from the drive and placed into the Output range.

The computer communicating with the sequential drive only communicates with the drive and not the changer. This allows the use of applications lacking library-specific, cartridge-movement, operating software.

Multiple tape drives can be configured for concurrent Sequential, Recycle or Dual-Bin operation. All random drives, and all cartridge locations not assigned to sequential drives, are still available for simultaneous Random mode operations.

This flexible design allows the user to partition the library's resources to best meet overall system needs. With a TLS-412180, for example, it is possible to have one library serve as the tape storage device for twelve separate systems.

2.16 Manual Operation

The menu system provides a means of manually moving cartridges to or from all available locations (drives, magazine slots, I/O Port). The menu system is accessed using the keys on the front panel. If the host makes a request to the TLS during a manual operation, the TLS indicates it is busy until the manual operation is completed (usually within a few seconds).

2.17 Logical Libraries

When shipped from the factory, all TLS-412xxx libraries look like a single library with all tape drives and storage slots dedicated to random operation. This is generally the correct configuration for a single system running a library aware backup application.

However, when multiple hosts are present and each needs to run a library specific backup application, then the TLS can be sub-divided into smaller *logical libraries*. This masquerade can be done for a total of four logical libraries – thereby making a single logical library do the work of up to four smaller ones.

Logical library partitioning is only possible when the hosts and the Medium Changer use SCSI to communicate. This feature is not available when the Medium Changer is connected via Fibre Channel.

3. Physical Specifications

3.1 Dimensions and Weights

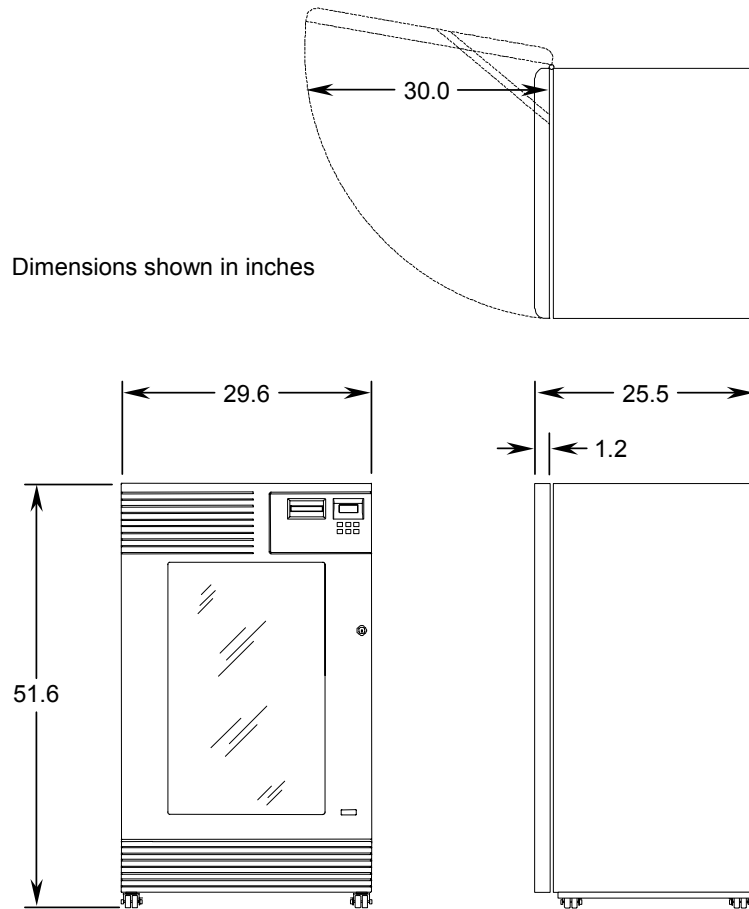

Figure 3-1 412180/360 External Dimensions

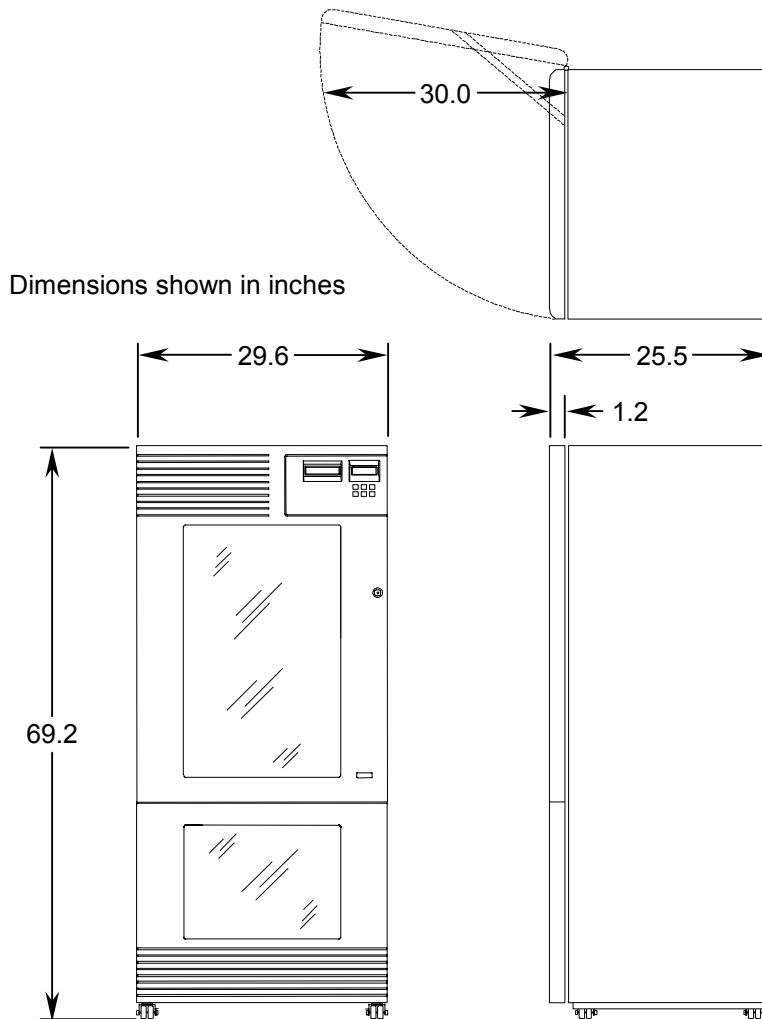

Figure 3-2 412300/600 External Dimensions

MODEL	HEIGHT (in/cm)	WIDTH (in/cm)	DEPTH (in/cm)	NET ^② WEIGHT (lb/kg)	SHIPPING ^① WEIGHT (lb/kg)
412180, 412360	51.6 / 131.1	29.6 / 75.2	25.5 / 64.0	261 / 118.4	456 / 206.8
412300, 412600	69.2 / 175.8	29.6 / 75.2	25.5 / 64.0	361 / 163.7	533 / 241.8

Table 3-1 Dimensions and Weights

- ① Shipping weights include the TLS, empty magazines and accessories. Add 2.5 pounds for each installed tape drive. Weight includes accessory carton(s) (shipped separately).
- ② Weight without tape drive, magazines or tape cartridges.

Other Weights	Weight (lb/kg)
Tape Drive	2.5 / 1.1
Magazine	0.9 / 0.4
Data Cartridge	0.15 / 0.07

Table 3-2 Other Weights

3.2 Standard Colors

The standard exterior color is beige.

Standard Color Specification: H.B. Fuller Industrial Coatings Division
IF 2044, Parchment Texture

3.3 Custom Logo Provision

The TLS is normally shipped with a Qualstar logo on the front of the unit. If specified at time of order, the logo may be either deleted, or the customer's logo substituted. The logo size is 1.72 in., by 0.62 in., by 0.06 in. thick, with 0.06 in. corner radii.

3.4 Tape Drive and Data Cartridge Compatibility

- The TLS-4000 series is designed to operate only with AIT tape drives supplied by Qualstar. Refer to Qualstar Product Information Note 014 for an up-to-date list of supported tape drives.
- The choice of media for use in the TLS is important. Only media approved by the tape drive manufacturer and Qualstar should be used in the TLS. Please refer to Qualstar Product Information Note 038 for the current list of approved media sources.
- **Data Cartridge Magazine** – Qualstar 10-cartridge magazine, P/N 501110-02-7

4. Electrical Specifications

4.1 Power Requirements and Consumption

The TLS operates with the following alternating current power sources:

Nominal Voltage Range	Nominal Line Tolerance	Maximum Operating Line Voltage	Minimum Operating Line Voltage	Line Frequency Range
100–120 VAC	+10%, -10%	254 VAC	90 VAC	48–62 Hz
200–240 VAC	+6%, -10%	254 VAC	90 VAC	48–62 Hz

No changes to the TLS are required to operate over either range.

Power consumption varies with the number of tape drives installed and the particular operation being performed. Table 4-1 is based on a full complement of tape drives installed in each model specified. The idle power figures indicate the power consumed when the robotic handler and tape drives are idle. The peak power figures indicate the peak power consumed when the carriage accelerates and the tape drives are active. The peak is not expected to last for more than two seconds at a time. The peak V-A (volt-amperes) figures are derived by dividing the peak power values by the TLS power factor.

MODELS	IDLE	PEAK	PEAK V-A	POWER FACTOR
412180, 412360	≤ 250 watts	≤ 405 watts	≤ 540 V-A	> 0.95
	≤ 854 BTUs/hr	≤ 1384 BTUs/hr		
412300, 412600	≤ 300 watts	≤ 455 watts	≤ 610 V-A	> 0.95
	≤ 1025 BTUs/hr	≤ 1554 BTUs/hr		

Table 4-1 Power Requirements

4.2 Power Source Disturbances

The TLS will continue to operate uninterrupted and without damage over a one-cycle line dropout. It is recommended that the TLS be powered from an Uninterruptible Power Source (UPS). The UPS should be rated to handle the peak V-A values indicated in Table 4-1.

4.3 Power Entry

The power switch, line fuse and line filter with I.E.C. power receptacle are mounted on the rear panel. An internal AC line filter reduces EMI conducted emissions and protects the TLS from noise on the power lines. A six-foot, seven-inch (2-meter) power cord is supplied for 120 VAC use in North America. For other destinations, a Harmonized HO5VV-F power cord is supplied.

4.4 Power Supplies

The TLS provides regulated DC power (+5V and +12V) for the tape drives on connectors which mate directly to the drives. There are four universal input, line switching power supplies in each model. These supplies feature a soft-start circuit to eliminate current surges on the AC mains when power is applied. They feature an over-voltage protection circuit that protects the robotics electronics and the tape drives in the event of a power supply failure.

The tape drive and robotic power supplies are Power Factor Corrected (PFC) to minimize harmonic distortion. All TLS-412xxx models comply with the requirements of EN-61000-3-2.

5.

Agency Compliance

5.1 EEC Directive Compliance (European Economic Community)

The TLS meets or exceeds the requirements of the CE Mark as set forth by:

- Electromagnetic Compatibility Directive 89/336/EEC
- Low Voltage Directive 73/23/EEC

5.2 Emissions/Immunity Standards Compliance

The TLS meets or exceeds the standards set forth by:

- FCC Rules, Part 15, Subpart B, Class A Computing Devices
- EN55022: 1998 Class A, EN55024: 1998, EN61000-3-2 and EN61000-3-3.

5.3 Safety Standards Compliance

The TLS meets or exceeds the standards set forth by:

- UL1950 Third Edition (United States)
- CAN/CSA-C22.2 No. 950-95 (Canada)
- EN 60950 (1992) with Amendments 1 and 2 (CB Scheme)

6. Performance Specifications

6.1 Data Cartridge Handling Times

Table 6-1 lists the Average Time to pick a cartridge from its storage location and place it in a drive, or pick a cartridge from a drive and return it to its storage location. Four seconds is the average time required for the shuttle mechanism to transfer a data cartridge between the carriages.

MODEL	AVERAGE TIME
412180	8 seconds
412360	8 seconds
412300	11.5 seconds
412600	11.5 seconds

Table 6-1 Cartridge Handling Times

6.2 Scan All Barcodes

In Table 6-2, the Typical Time values are the times required to scan a full complement of data cartridges. This assumes all cartridges are barcoded and that no retries are needed.

MODEL	TYPICAL TIME
412180	65 seconds
412360	65 seconds
412300	82 seconds
412600	154 seconds

Table 6-2 Barcode Scanning Times

7. Environmental Specifications

7.1 Temperature, Humidity and Altitude

PARAMETER	OPERATING	NON-OPERATING ①
Ambient temperature	+5 °C to +32 °C (+41 °F to +90 °F)	-20 °C to +60 °C (-4 °F to +140 °F)
Temperature gradient (maximum)	1 °C/minute, 10 °C/hour (2 °F/minute, 18 °F/hour)	1 °C/minute, 20 °C/hour (2 °F/minute to +36 °F/hour)
Relative humidity (non-condensing)	20% to 80%	10% to 90%
Wet bulb temperature	26 °C (79 °F) maximum	29 °C (84 °F) maximum
Altitude	-1000 to +10,000 feet -304.8 to +3,048 meters	-1000 to + 40,000 feet -304.8 to +12,192 meters

① Storage and transportation for the TLS only – tape drives and media excluded.

Table 7-1 Environmental Specifications

NOTE

Rapid changes in temperature which produce condensation must never be allowed since the condensed liquid may contaminate bearing lubricants and possibly shorten the expected Mean Time Between Failures.

7.2 Acoustical Noise

Overall noise level at one meter from the front of the TLS, shall not exceed:

- With all tape drives operating: ≤ 50 dBA
- All tape drives plus robotic handler operating: ≤ 65 dBA

8.

Reliability Specifications

8.1 Mean Exchanges Between Failures

The demonstrated Mean Exchanges Between Failures (MEBF) rating exceeds 1,000,000 exchange cycles. The MEBF rating excluded tape drives which are rated separately by their manufacturer. An exchange cycle consists of the following actions:

1. Pick a data cartridge from a storage location.
2. Place the cartridge into a tape drive.
3. Remove a cartridge from a drive.
4. Return the cartridge to a storage location.

Qualstar Corporation does not warrant either the MEBF or the historical failure rate to be representative of any particular unit installed for customer use. Failure rates are derived from a large database of test samples. The individual failure rate will vary from unit to unit.

9.

Maintainability

9.1 Mean Time To Repair

The Mean Time To Repair (MTTR) shall not exceed 30 minutes. The MTTR is the average time for an adequately trained and equipped technician to diagnose and correct a malfunction while following the service procedures in the Technical Service Manual. Servicing will be limited to replacing major subassemblies and printed circuit board assemblies (PCBAs). Repair time does not include system retest time.

9.2 Preventive Maintenance

The only routine preventive maintenance required by the TLS consists of periodically cleaning and replacing the air filters, which are located on the rear panel. The TLS keeps track of its power-on hours in order to periodically remind the user to replace the filter. After replacement, the user clears the maintenance reminder via the menu system. The replacement interval can be changed to match the local environmental conditions.

9.3 Automated Tape Drive Cleaning

A feature of the TLS allows the user to specify a storage location where a cleaning cartridge can be stored for each tape drive. Any number of cleaning cartridge locations from none, up to the number of drives may be specified, but each drive can have only one location. Cleaning cartridge locations are not restricted from the resources available to random or sequential operations.

A menu allows the user to specify a drive to be cleaned. If the drive is empty, the TLS will move the predetermined cleaning cartridge to the drive. When the drive ejects the cartridge, the TLS will return it to its original location.

If the host's software supports automated tape drive cleaning, then the task can be completely automated.

9.4 Adjustments

The TLS does not require electrical or mechanical adjustments after any field replaceable unit (FRU) or tape drive is replaced. All adjustments, alignments and calibrations are performed automatically.